

MAINTENANCE AND OPERATION
INSTRUCTION MANUAL

DB8009-MPX

MPX & Audio Silence Monitor
with Advanced Backup Capabilities



Contents

Introduction	6
Typographic conventions	7
General Information	8
Product Features	9
<i>Technical Specifications</i>	10
<i>Block Diagram</i>	13
Safety Warning	14
Operating Recommendations	15
Unpacking and inspection	16
Mounting	16
<i>Rack Requirements 1U</i>	16
<i>Rack Requirements Compact Units</i>	16
<i>Stand-Alone Devices</i>	16
AC Mains Power	17
<i>Fuse holder</i>	17
<i>Mains Voltage Selector</i>	17
<i>Power cord</i>	17
<i>Ground Loops</i>	17
Panel Indicators and Connectors	18
<i>Front Panel</i>	18
<i>Rear Panel</i>	19
<i>GPIO Connector Pinouts</i>	20
<i>Electrical Characteristics of Optocouplers</i>	20
Navigation Through LCD Menu	21
<i>The Basics</i>	21
<i>Menu Structure</i>	22
<i>Restore Factory Defaults</i>	32
Connecting DB8009-MPX	33
<i>Analog Audio Inputs</i>	33
<i>Digital Audio Input</i>	33
<i>LAN Port</i>	33
Operation	34
<i>Manual IP Identification</i>	34
<i>Network Discovery</i>	36
DB8009-MPX WEB interface menu pages	38
<i>Status</i>	38
<i>Input</i>	39
<i>Main and AUX MPX In Meter Calibration</i>	39
<i>Main and AUX Digital Input</i>	39
<i>Main and AUX Analog Input</i>	39
<i>MP3 Audio Player</i>	39
<i>MP3 Files Upload via FTP</i>	39
<i>IP Audio Client</i>	40
<i>Jingle Player</i>	40
<i>Jingle Files Upload via FTP</i>	40
<i>How can a playlist file be made?</i>	40

<i>Backup</i>	41
<i>Audio Loss and Audio Recovery and MPX Loss and Recovery</i>	41
<i>MPX Monitor Mode</i>	41
<i>How the device works</i>	41
<i>Stereo Generator</i>	42
<i>General</i>	42
<i>Injection levels</i>	42
<i>Stereo Adjustment</i>	42
<i>MPX ITU Limiter</i>	42
<i>Basic RDS</i>	43
<i>Dynamic RDS</i>	45
<i>Dynamic PS</i>	45
<i>Radio Text</i>	46
<i>PTYN (Program Type Name) Settings</i>	46
<i>Date & Time Settings</i>	46
<i>Console Settings</i>	46
<i>How to connect to the RDS Console</i>	47
<i>RDS Console syntax</i>	47
<i>List of available RDS console commands and their responses</i>	48
<i>Output</i>	49
<i>MPX Output</i>	49
<i>Analog Audio</i>	49
<i>Digital Audio</i>	49
<i>Headphones</i>	49
<i>IP Voice Announcement</i>	49
<i>Dayparts</i>	50
<i>General</i>	51
<i>Network</i>	52
<i>Network</i>	52
<i>E-mail</i>	52
<i>HTTP Server</i>	53
<i>FTP Server</i>	53
<i>SNMP Agent</i>	53
<i>Other</i>	54
<i>Firmware Update</i>	54
<i>Storage</i>	54
<i>Factory Defaults</i>	54
<i>Reboot</i>	54
<i>System Log</i>	55

UPnP discovery in Local Networks	56
UPnP Activation	57
APPENDIX A	58
<i>RDS: Europe vs America</i>	<i>58</i>
<i>The RDS System</i>	<i>58</i>
APPENDIX B.1	59
<i>PTY Code Description Used in RBDS Mode – North America.....</i>	<i>59</i>
APPENDIX B.2	60
<i>PTY Code Description Used in RDS Mode – Europe, Asia</i>	<i>60</i>
APPENDIX C	61
<i>How should I configure the connection between my DEVA Device and an FTP Client?</i>	<i>61</i>
WARRANTY TERMS AND CONDITIONS.....	63
Product Registration Card.....	64

THIS PAGE
IS INTENTIONALLY
LEFT BLANK

Introduction

DEVA Broadcast Ltd. is an international communications and high-technology manufacturing organization, its corporate headquarters and facility located in Burgas, Bulgaria. The company serves the broadcast and corporate markets worldwide – from consumers and small businesses to the largest global organizations. It is dedicated to the research, design, development and provision of advanced products, systems and services. DEVA Broadcast launched its own brand back in 1997 and has nowadays evolved to become known as a market leader and internationally reputed manufacturer of user-friendly, cost-effective and innovative broadcast products.

Creativity and innovation are deeply woven into DEVA Broadcast corporate culture. Through successful engineering, marketing and management our team of dedicated professionals creates future-oriented solutions to improve customers' performance. You may rely that all issues communicated to our crew would be addressed accordingly. We pride ourselves on our pre and post-sales support and purchase services, which along with the outstanding quality of our radio gear have won us due respect and the market authority position.

DEVA Broadcast best-of-breed solutions have become the best sellers for our partners. The strategic partnerships which have been formed with industry leaders during all these years that we have been operating on the broadcasting market, have proved us a reliable business partner and a valuable asset, as our dealers worldwide would confirm. In constant pursuit of precision and long-term satisfaction, DEVA Broadcast enhances the reputation of our partners and clients alike. Furthermore, we have already a proven merit as a credible partner provider.

Our portfolio offers complete line of high quality and competitive products for FM and Digital Radio, Radio Networks, Telecommunication Operators and regulation authorities. For almost two decades of intensive software and hardware development, we have achieved a unique price-performance and endurance of our product lines. Our company's multitude of equipment and services is in line with the latest technologies and key trends. The most recognizable characteristics attributed to DEVA Broadcast products are their clear-cut, streamlined design, easiness of use and cost-effectiveness: simplicity of forms but multiplicity of functions.

For us there is no stage when we deem that we have reached the most satisfactory level in our work. Our engineers are in constant pursuit of new ideas and technologies to be captured in DEVA Broadcast solutions. Simultaneously, a strict control is being exercised at each step of any new development. Experience and hard work are our fundament but the continuous improving process is what we never leave aside. DEVA Broadcast participates on a regular basis in all landmark broadcasting events, not only to promote its products, but to exchange valuable know-how and experience. We are also engaged in international large-scale projects involving radio and audio solutions which makes us even more competitive on the global market.

All DEVA Broadcast products are developed and produced in accordance with the latest ISO 9001 quality control standards.

Typographic conventions

The following table describes important conventions used in the manual.

Convention and Style	Description	Examples
<i>Menu > Sub Menu > Menu Command</i>	A menu item(s) and menu command that you need to click in sequence	Click <i>Settings > General</i>
[Button]	Interface Interactive buttons	Press [OK] to save the changes
NOTE	Important notes and recommendations	NOTE: The notification will appear only once
<u>“Reference Name” on Page XXX</u>	References and links	refer to <u>“New Connection”</u> (see <u>“Monitoring” on page 56</u>)
Example	Used when example text is cited	Example for E-mail Notification: Date: 04 Nov 2013, 07:31:11

General Information

DEVA's DB8009-MPX is an exceptional example of a top-notch silence detector that continues the company's hugely successful range of broadcast tools but at the same time stands apart in terms of the functionalities it provides users with. It guarantees highly dependable monitoring of the Composite Stereo signal, Analog and Digital Audio feed and in case of signal loss automatically switches over to one of a number of available backup sources.

Crucially, however, the most notable advantage of this product are the MPX inputs and outputs providing precise MPX monitoring and backup capabilities. Similarly to other tools in this product line, the DB8009-MPX also offers the familiar MP3 and IP Audio backup options. Its design incorporates a fully DSP-based Stereo Encoder which provides an MPX signal at the output even if the backup source has been set as Analog, Digital or IP Audio.

The unit can be easily configured and monitored by users via SNMP, the WEB Interface, the front panel LCD display and the set of soft buttons. Another important feature is its capability for alert notifications which, in case radio silence is detected, can be generated via email, SNMP or analog opto-coupled outputs.

The DB8009-MPX provides UPnP for easy discovery in local networks, as well as digital volume control of all audio sources, and can be incorporated effortlessly into the setup of either a single station or large radio networks. Through a standard FTP client, MP3 backup files can be uploaded onto the device, which also has a 4GB storage capacity ensuring no repetition of audio tracks for over 24 hours of playback.

The DB8009-MPX is a model that combines the immaculate monitoring performance of DEVA's products with the much-valued precision of the Analog, Digital Audio and MPX silence detection to deliver a constant, uninterrupted audio feed.

Product Features

- Fully DSP based core
- Intelligent Silence Detector and Backup Audio Switcher
- User selectable backup audio sources priority
- Configuration and Monitoring via SNMP, WEB, Front Panel LCD and Keyboard
- Alert Notifications via E-mail, SNMP
- Lots of Storage for over 24 hours of non-repeating audio playback
- Always Fresh Backup Audio Tracks with Embedded FTP server
- Professional Balanced Stereo analog inputs and outputs on XLR connectors
- Professional AES/EBU Digital audio inputs and output on XLR connectors
- Headphones Jack on the front panel for local monitoring of the Audio Signal
- TCP/IP Remote monitoring and control via SNMP and WEB Interface
- Multi-format IP Audio Stream (three separate sources)
- Built-in MP3 Player
- External or internal Digital clock sync
- Digital Volume Control of all Audio Sources
- Protected access to the device settings
- UPnP for easy discovery in Local Networks
- Professional 19 inches, 1U aluminium rack mount chassis
- Wide Range Internal Power Supply 100-240VAC 50-60Hz
- Easy installation and operation
- Remote Firmware Upgrade for future-proof operation
- 2 Years Warranty

TECHNICAL SPECIFICATIONS

MAIN MPX (COMPOSITE) INPUT	
Connector	BNC Unbalanced
Impedance	10 k Ω
Frequency Range	10 Hz to 200 kHz
Level	100% reference in range -12dBu to +18dBu, 0.1dB step, software controlled
MAIN ANALOG AUDIO INPUTS	
Connectors	Balanced XLR
Impedance	600 Ω or high impedance
Level	0dBFS reference in range -12dBu to +18dBu, 0.1dB step, software controlled
Dynamic range	>80dB
Digital Gain Adjust	-10db to +10dB
MAIN DIGITAL AUDIO INPUTS	
Connectors	Balanced XLR, Coaxial
Sample Rates	32, 44.1, 48, 96 kHz
Digital Gain Adjust	-10db to +10dB
AUX MPX (COMPOSITE) INPUT	
Connector	BNC Unbalanced
Impedance	10 k Ω
Frequency Range	10 Hz to 200 kHz
Level	100% reference in range -12dBu to +18dBu, 0.1dB step, software controlled
AUX ANALOG AUDIO INPUTS	
Connectors	Balanced XLR
Impedance	600 Ω or high impedance
Level	0dBFS reference in range -12dBu to +18dBu, 0.1dB step, software controlled
Dynamic range	>80dB
Digital Gain Adjust	-10db to +10dB
AUX DIGITAL AUDIO INPUTS	
Connectors	Balanced XLR, Coaxial
Sample Rates	32, 44.1, 48, 96 kHz
Digital Gain Adjust	-10db to +10dB

IP AUDIO SOURCE	
Number of Streams	one main and two alternative streams with auto-switch on failure
Stream Clients	shoutcast, icecast
Stream Formats	PCM, MPEG1 Layer 3 (MP3), HE-AAC (v.1 and v.2); all at 32, 44.1, 48kHz only
Bit Rates	All standard bit rates, including VBR
Number of Channels	Mono, Stereo
Buffer Size Adjust	5Kb to 64Kb
Digital Gain Adjust	-10db to +10dB
BUILT-IN MP3 PLAYER	
Storage Capacity	2Gb on SD Card
Supported encoders	HE-AAC (v.1 and v.2), MPEG-1 Layer 3
MP3 bit rates	32-320 kbps and VBR
Sample rates	All sampling frequencies specified by MPEG1 L1/L2/L3 (32, 44.1 and 48kHz)
Supported file types	*.MP3, *.AAC, *.M4A, *.M3U
Playback modes	Alphabetical ascending and descending, Shuffle, Playlist and Shuffled playlist
Remote file management	Build-in FTP server
Digital Gain Adjust	-10db to +10dB
MPX (COMPOSITE) OUTPUT	
Connector	BNC Unbalanced, EMI suppressed
INTERNAL STEREO ENCODER	
Output level	Up to +12dBu, 0.1dB step, software controlled
Pilot level	0% to 15%
D/A conversion	24 bit, differential
SNR	>80 dB (20Hz - 15kHz bandwidth, Digital input referenced to -10dBFS, unweighted)
THD	< 0.01% (20Hz - 15kHz bandwidth, Digital input referenced to -10dBFS, unweighted)
Stereo Separation	>60dB
Crosstalk	>70dB
Pilot protection	>90dB relative to 9% pilot injection, ± 250 Hz
38 kHz suppression	>80dB (referenced to 100% modulation)
ANALOG AUDIO OUTPUT	
Connector	Balanced XLR
Frequency response	± 0.5 dB, 5Hz-20kHz
Distortion	<0.01% THD+N
Level	Up to +18dBu, 0.1dB step, software controlled
Dynamic range	>80dB
DIGITAL AUDIO OUTPUTS	
Connectors	Balanced XLR, Coaxial
Sample rates	32, 44.1, 48kHz

PHONES AUDIO OUTPUT	
Connector	1/4" (6.3mm) jack, stereo
Type	Headphones
AUDIO SILENCE DETECTOR	
Loss Threshold	Adjustable -90dBFS to 0dBFS
Trigger time	1 - 240s
Recover Threshold	Adjustable -90dBFS to 0dBFS
Recover time	1 - 240s
MPX SILENCE DETECTOR	
Loss Threshold	Adjustable 0% to 100%
Trigger time	1 - 240s
Recover Threshold	Adjustable 0% to 100%
Recover time	1 - 240s
USER INTERFACE	
Indicators	5 LEDs on front panel, 2 LEDs on rear panel
Web interface	control, configuration and status information
SNMP interface	control, configuration and status information
Front Panel	LCD with Keyboard
NETWORK	
Connector	RJ-45
Type	Ethernet
Device Discovery	UPnP support
OPERATING CONDITIONS	
Temperature	10°C - 45°C
Humidity	< 75%, non-condensing
POWER REQUIREMENTS	
Voltage	115/230V AC (internal switch), 18VA
Connector	IEC320, rear panel
SIZE AND WEIGHT	
Dimensions (W;H;D)	483 x 45 x 160 mm
Shipping Weight	540 x 115 x 300 mm / 2.9kg

BLOCK DIAGRAM

A simplified block diagram of DB8009-MPX is shown below

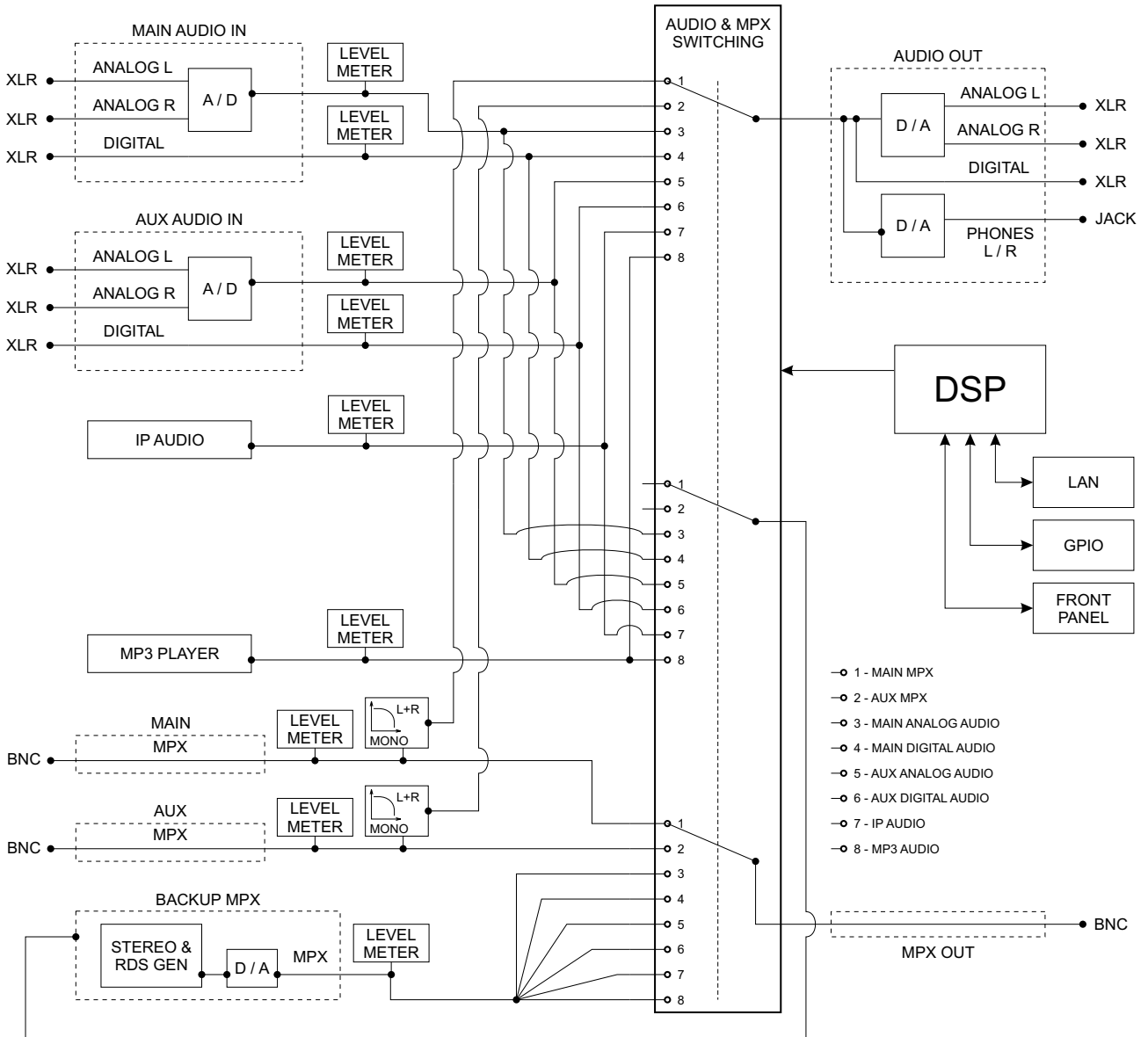

Because of the all-digital, minimalist-discrete-component nature of device circuitry, we have not provided schematic diagrams of the DB8009-MPX in this Manual. Please, note that:

**NO USER-SERVICEABLE COMPONENTS INSIDE.
 REFER ALL SERVICING TO
 QUALIFIED TECHNICAL PERSONNEL.**

Safety Warning

ALWAYS OBSERVE THE SAFETY PRECAUTIONS.

Careful observance of the safety precautions will help prevent physical injury, damage of the equipment, and extend the equipment life.

- The servicing of electronic equipment should be performed only by qualified personnel;
- Before removing the covers the unit must be switched off and the mains cable unplugged;
- When the equipment is open, the power supply capacitors should be discharged using a suitable resistor;
- Never touch the wires or the electrical circuits;
- Use insulated tools only;
- Never touch the metal semiconductor. They might carry high voltages;
- For removing and installing electronic components, follow the recommendations for handling MOS components.
- Do not remove the factory sticker from the equipment. It contains information as regards the name, serial number and MAC address of the device.
- To join the equipment to the mains supply, use the power cord purchased with the equipment.

Operating Recommendations

To ensure normal operation of the DEVA unit, we recommend following the instructions listed below.

- Install the unit in places with good air conditioning. The unit is designed to operate within the ambient temperature range of 10 to 50°C. The equipment rack should be ventilated in order for the device to keep its internal temperature below the maximum ambient temperatures;
- We do not recommend installation in rooms with high humidity, dusty places or other aggressive conditions;
- Although the device is intended to be installed closed to exciters or transmitters, we do recommend the device to be located away from abnormally high RF fields.
- Use only checked power supply cables. We strongly recommend the usage of shielded cables;
- Connect the DEVA unit to reliable power supply sources only. In case of unstable power supply, please use Uninterruptible Power Supply (UPS);
- Use the device only with its top cover on to avoid electromagnetic anomalies. Otherwise, this may cause problems with the normal functionality of the unit;
- To ensure normal remote operation of the unit, make sure to connect the device to a good quality Internet connection;
- For the normal operation of your DEVA device, check if the network settings past through all the required data traffic.

Unpacking and inspection

Upon receipt, the equipment should be inspected for possible shipping damages. If such are found or suspected, notify the carrier at once and contact DEVA Broadcast Ltd. The original shipping carton box and packing materials should be kept for possible reuse, in case of return for Warranty repair, for example. Shipping damages as a result of improper packing for return may invalidate the Warranty!

The packing material (plastic bags, polystyrene, nails, etc.) must never be left within reach of children, as these items are potential sources of danger.

IT IS VERY IMPORTANT that the [“Product Registration Card”](#) included in the Manual be completed accurately and returned. This will assure coverage of the terms of the Warranty and it will provide a means of trace in case of lost or stolen equipment. In addition, the user will automatically receive SERVICE OR MODIFICATION INSTRUCTIONS from DEVA Broadcast Ltd.

Mounting

RACK REQUIREMENTS 1U

The unit mounts in a standard 19-inch equipment rack and requires only 1 $\frac{3}{4}$ inches (1U) of vertical rack space. In order the painted finish around the mounting holes to be protected, the use of plastic washers is recommended.

RACK REQUIREMENTS COMPACT UNITS

Our customized 1U 19-inch rack accessory provides a professional mounting option for up to three compact size DEVA units. It is made of milled aluminum and finished in black powder coat. Two extra blanking panels and set of mounting screws are provided with each rack bracket kit.

STAND-ALONE DEVICES

DEVA's stand-alone units (Radio Explorer series, BandScanner series, DVB Explorer) do not require additional tools or installation brackets.

AC Mains Power

FUSE HOLDER

The fuse holder is placed inside the unit, next to the voltage selector. Apply downward pressure and pull the cap outward to access the 5mm mains fuse. The reverse process will release the cap.

MAINS VOLTAGE SELECTOR

Before connecting the AC Power, make sure that the internal Power Switch is in accordance with the mains supply at your location. The Power Supply Factory Settings are:

- 100 - 240 VAC
- 1 Amp Fuse

CAUTION: Permanent damage will result if improper AC supply voltage is applied to the device. The warranty DOES NOT cover damages caused by applying improper supply voltage or usage of improper fuse.

POWER CORD

The detachable IEC-type power cord is supplied with the unit. The individual cord conductors may be color-coded in either of two ways:

1) In accordance with US standards:
BLACK = AC "HOT"
WHITE = AC NEUTRAL
GREEN = EARTH GROUND

2) To European CEE standards:
BROWN = AC "HOT"
BLUE = AC NEUTRAL
GREEN/YELLOW = EARTH GROUND

GROUND LOOPS

Because the unbalanced INPUTS/OUTPUTS of the device are chassis-ground-referenced, a mains frequency or INPUT/OUTPUT ground loop could be formed between the input or output cable shield grounds and the AC power cord ground. A 'ground-lifting' AC adapter may help in this situation, although the chassis must be properly grounded for safety purposes. In general, the equipment being installed in a rack will satisfy the safety requirement.

Panel Indicators and Connectors

FRONT PANEL

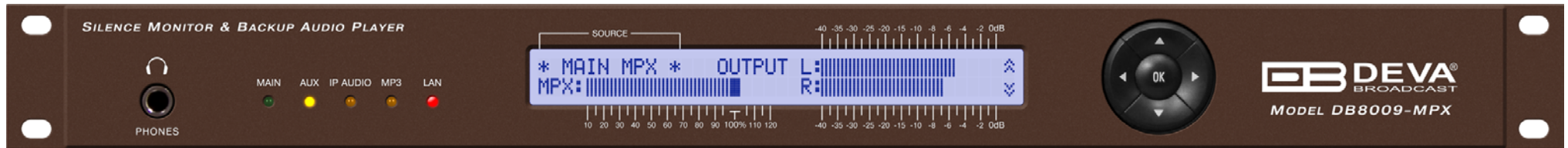

- PHONES – Stereo 1/4” (6.3 mm) jack output for headphones. Only the selected Silence detection audio will be heard through the headphones;
- MAIN – indicates that the Main Source Input is active;
- AUX – indicates that the Auxiliary Source Input is active;
- IP AUDIO - indicates that the IP Audio Stream is active;
- MP3 – indicates that the MP3 player is active;
- LAN – indicates LAN presence;
- LED Display with scales;
- FRONT PANEL NAVIGATION MENU

REAR PANEL

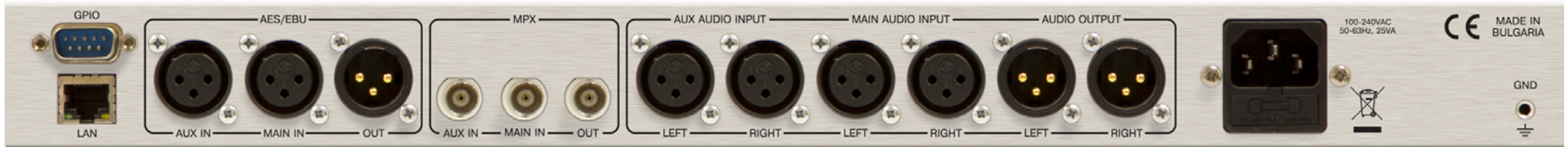

GPIO

LAN – RJ-45 connector for TCP/IP connection;

AES/EBU:

- Auxiliary Digital Input
- Main Digital Input
- Digital Output

MPX :

- Auxiliary Input
- Main Input
- Output

AUX AUDIO INPUTS – Analog Inputs (Left and Right) - XLR Type;

MAIN AUDIO INPUTS: Analog Inputs (Left and Right) - XLR Type;

AUDIO OUTPUT: Analog Outputs (Left and Right) - XLR Type;

AC 115V/230V – Mains connector, IEC320 type.

GPIO CONNECTOR PINOUTS

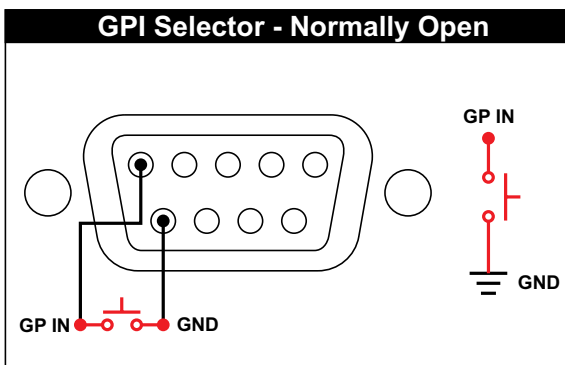
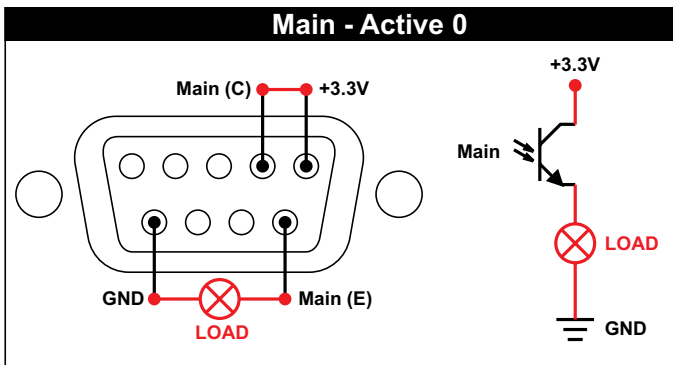
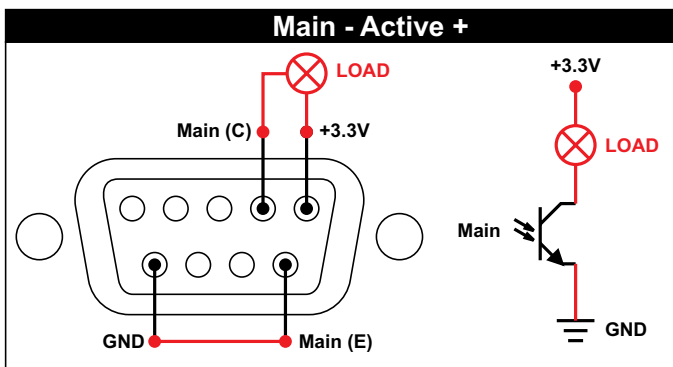
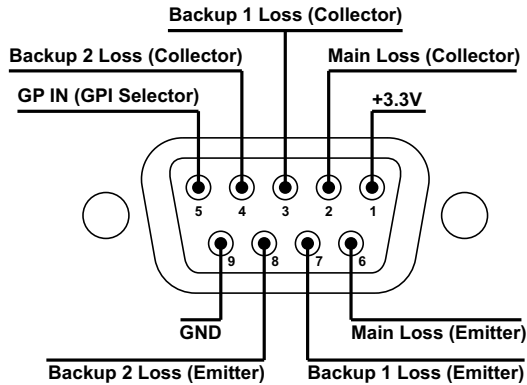

Electrical Characteristics of Optocouplers

$V_{ec} < 6V$ $I_c < 50mA$
 $V_{ce} < 70V$ $P_d < 150mW$

Navigation Through LCD Menu

THE BASICS

DB8009-MPX has an easy to read, LCD screen that visualizes all measurements of the received signal and settings. Upon switching it on, the Company Logo and model of the device will be displayed. After a few seconds the Start-up screen will disappear, replaced by the Main Screen. This is the starting point of the navigation process.



After the Initial screen disappears (in a few seconds), it will be replaced by the Main Menu readings.



This is the starting point of the navigation process.

Prior to proceeding further in the menu structure, it is important to note the basic functionality - the keyboard (placed on the right of the LCD Screen) consists of [Up], [Down], [Left], [Right] and [OK] buttons. The Main Menu structure has an up-and-down basis, expanded with left-to-right branches.

MENU STRUCTURE

The following block diagram shows expanded view of the menu structure. To switch between the different pages use the denoted Buttons.

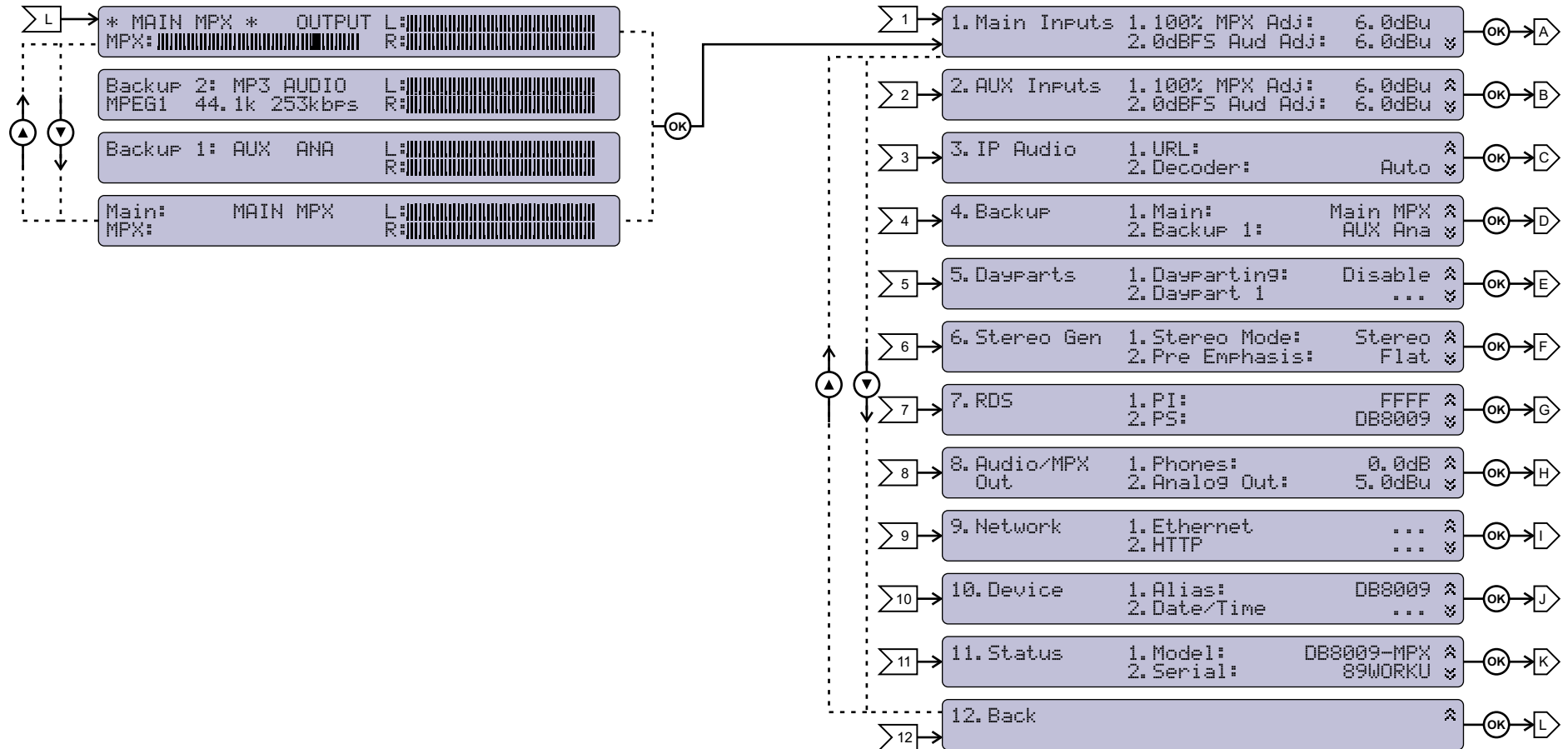

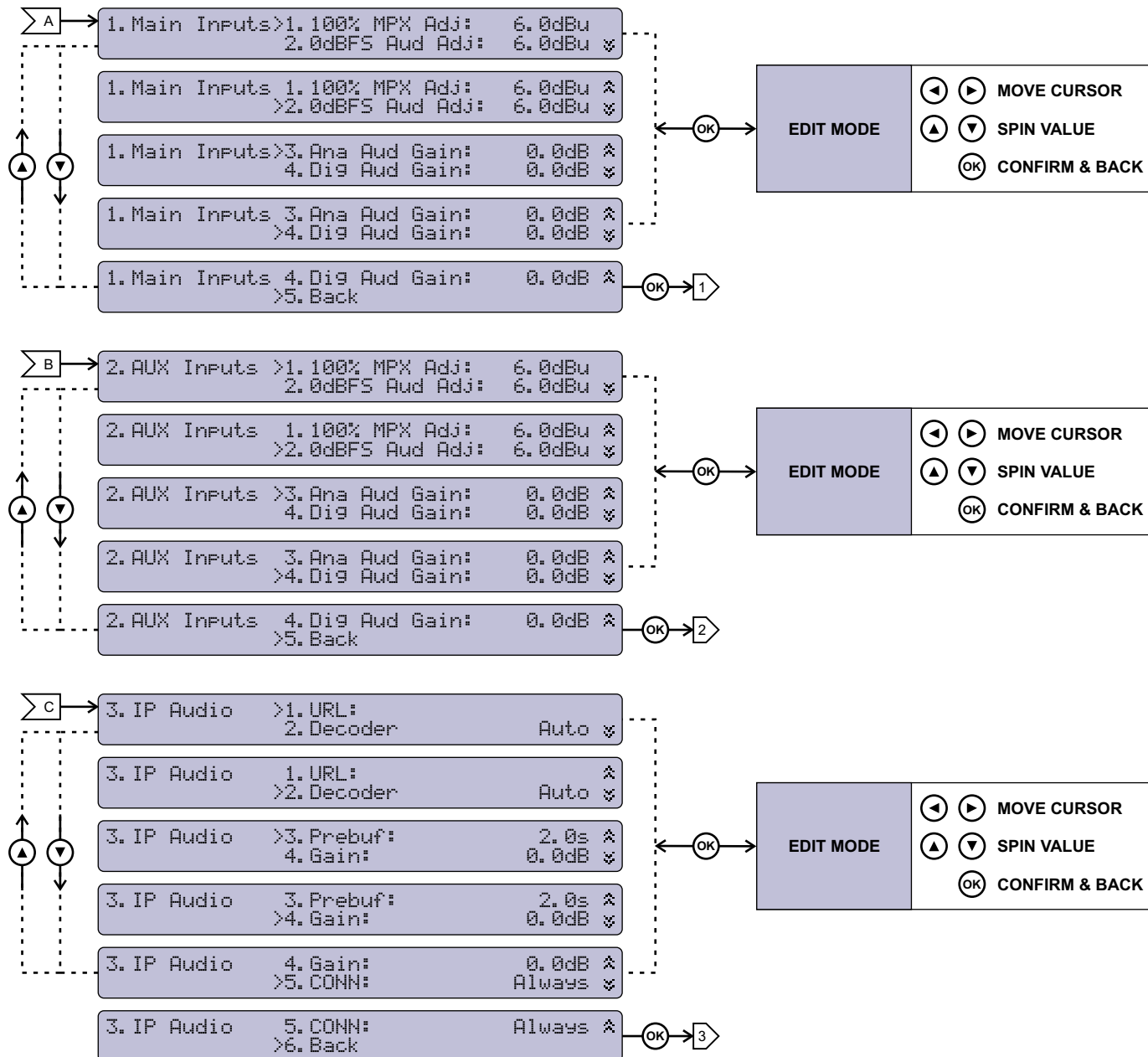

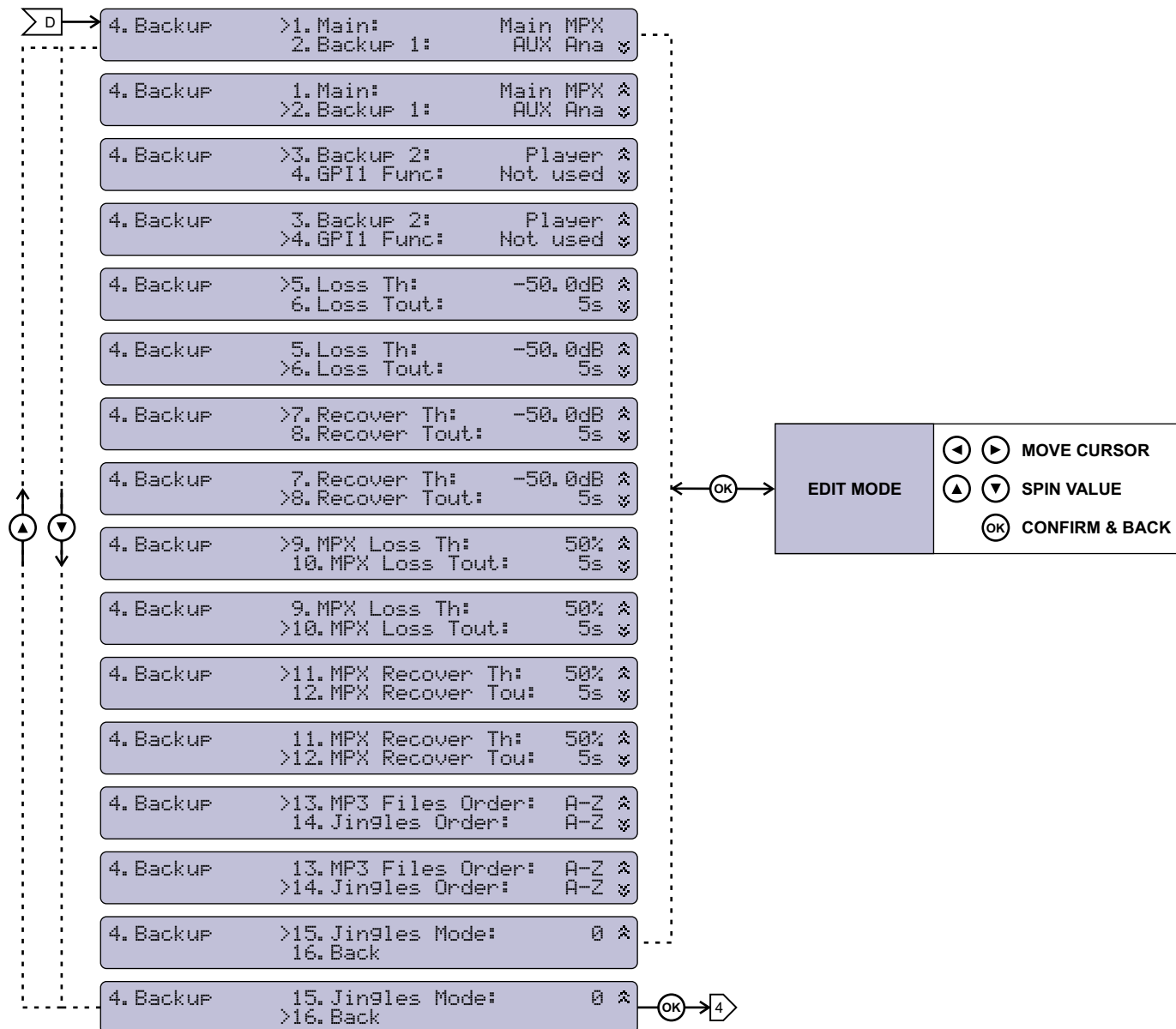

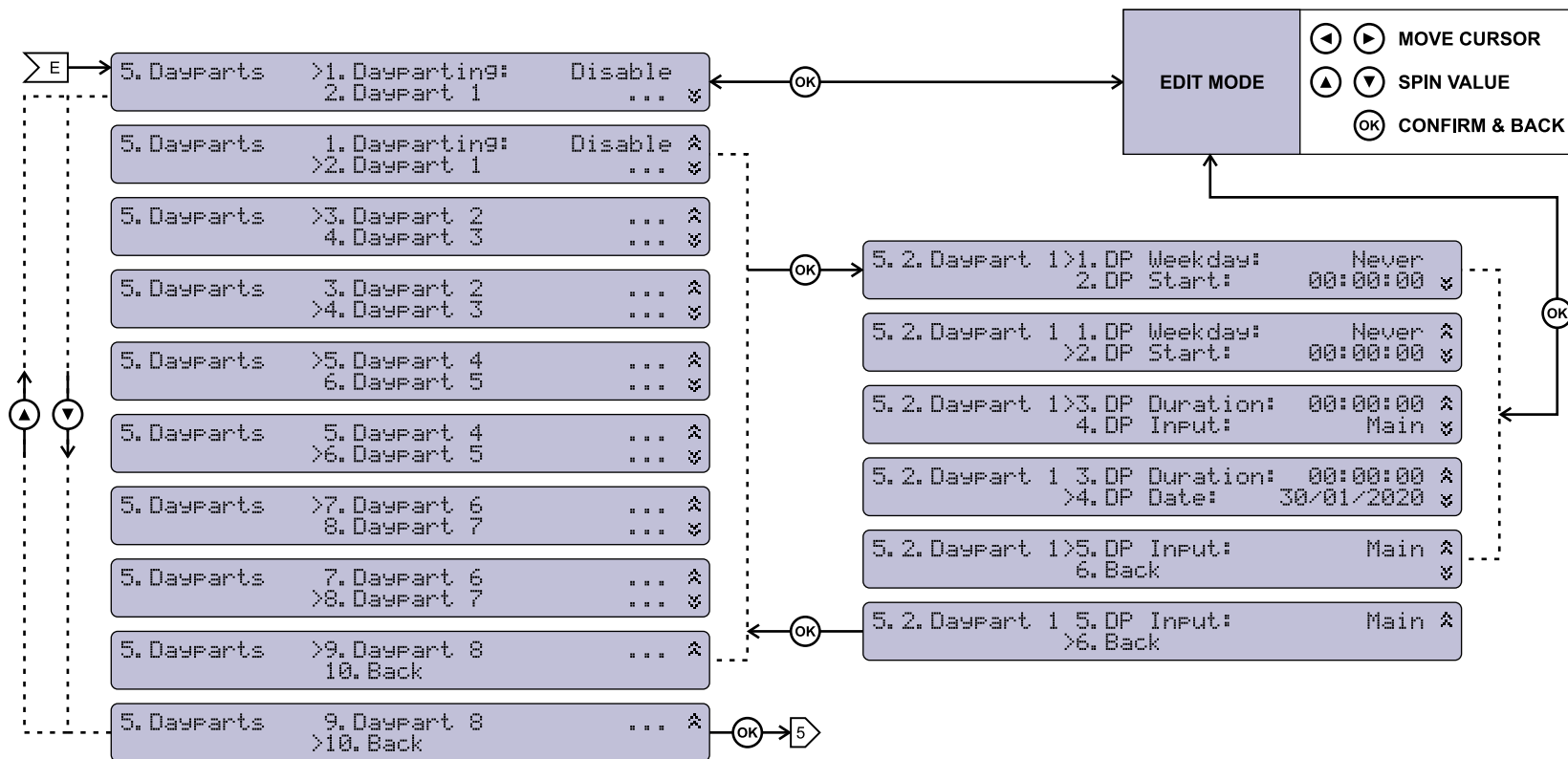

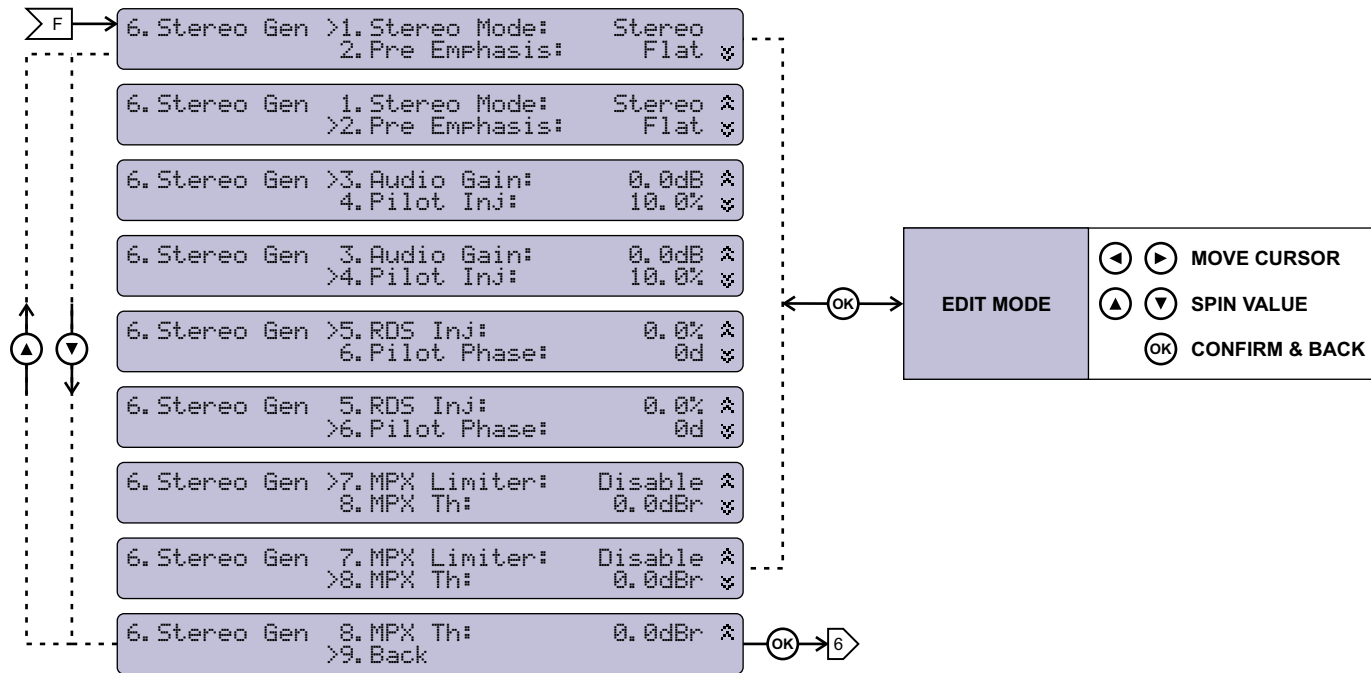

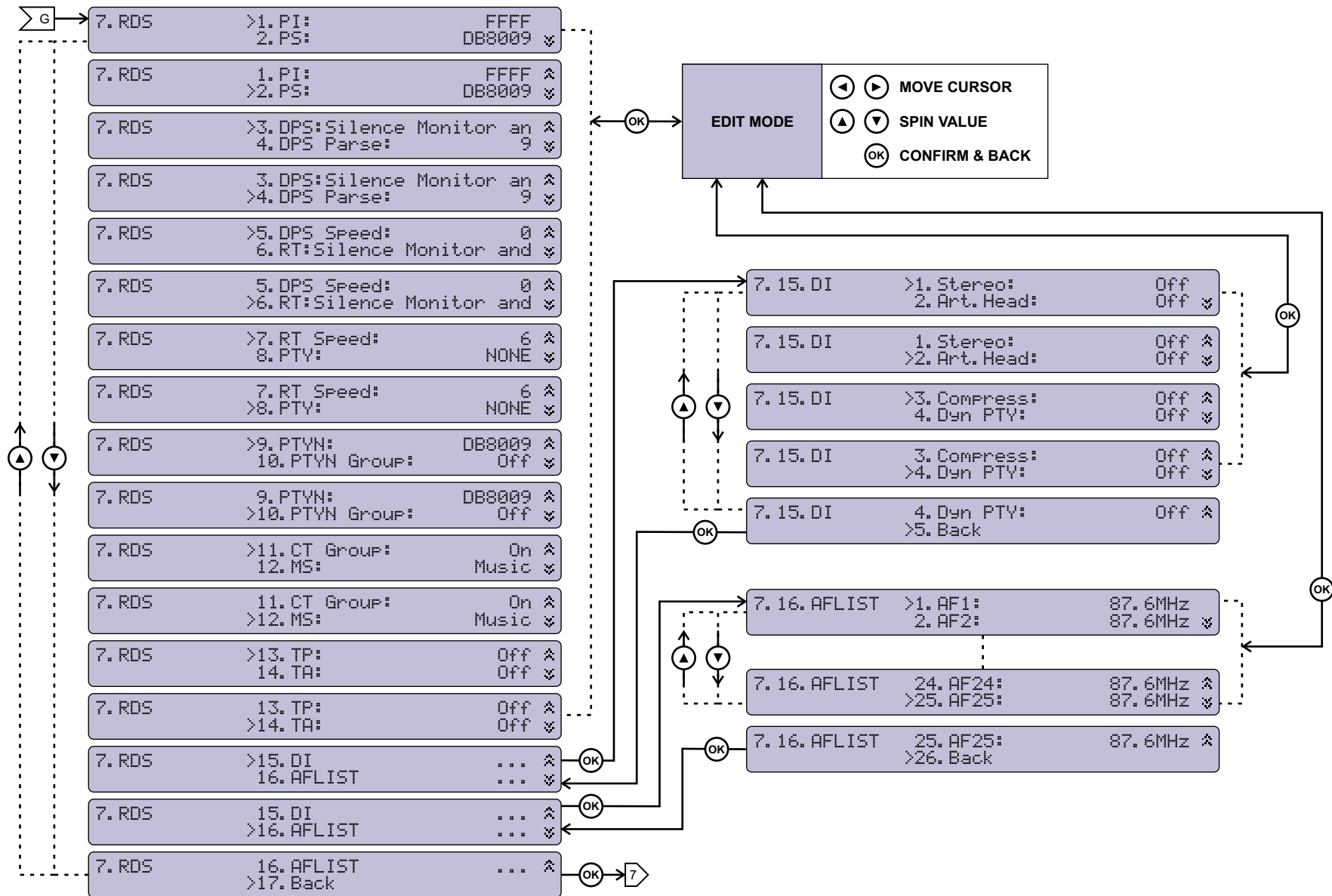

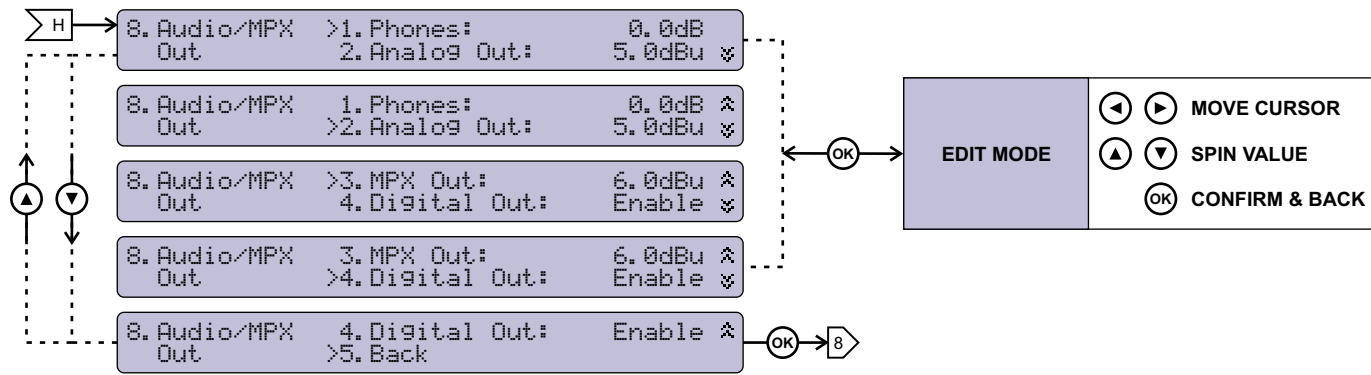

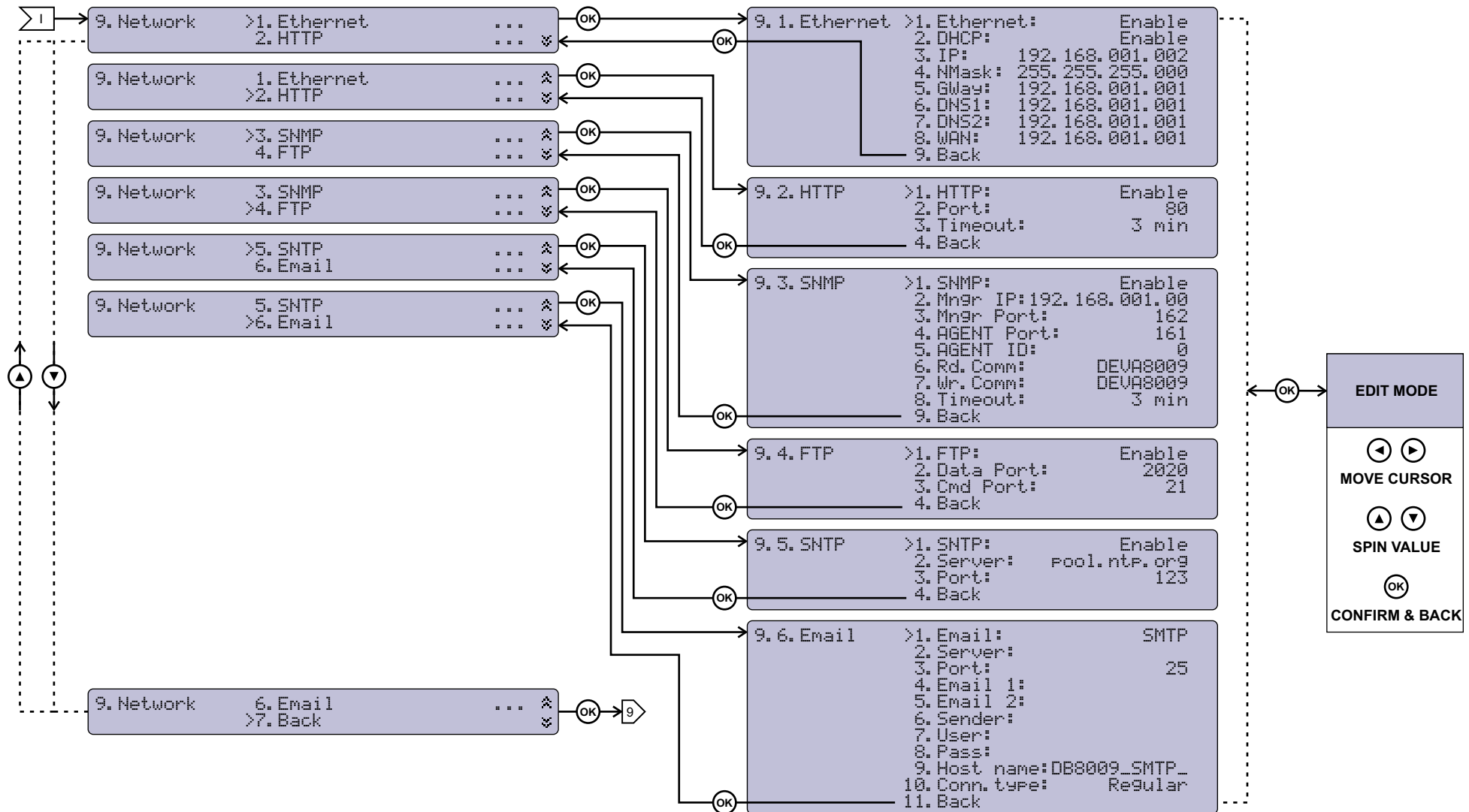

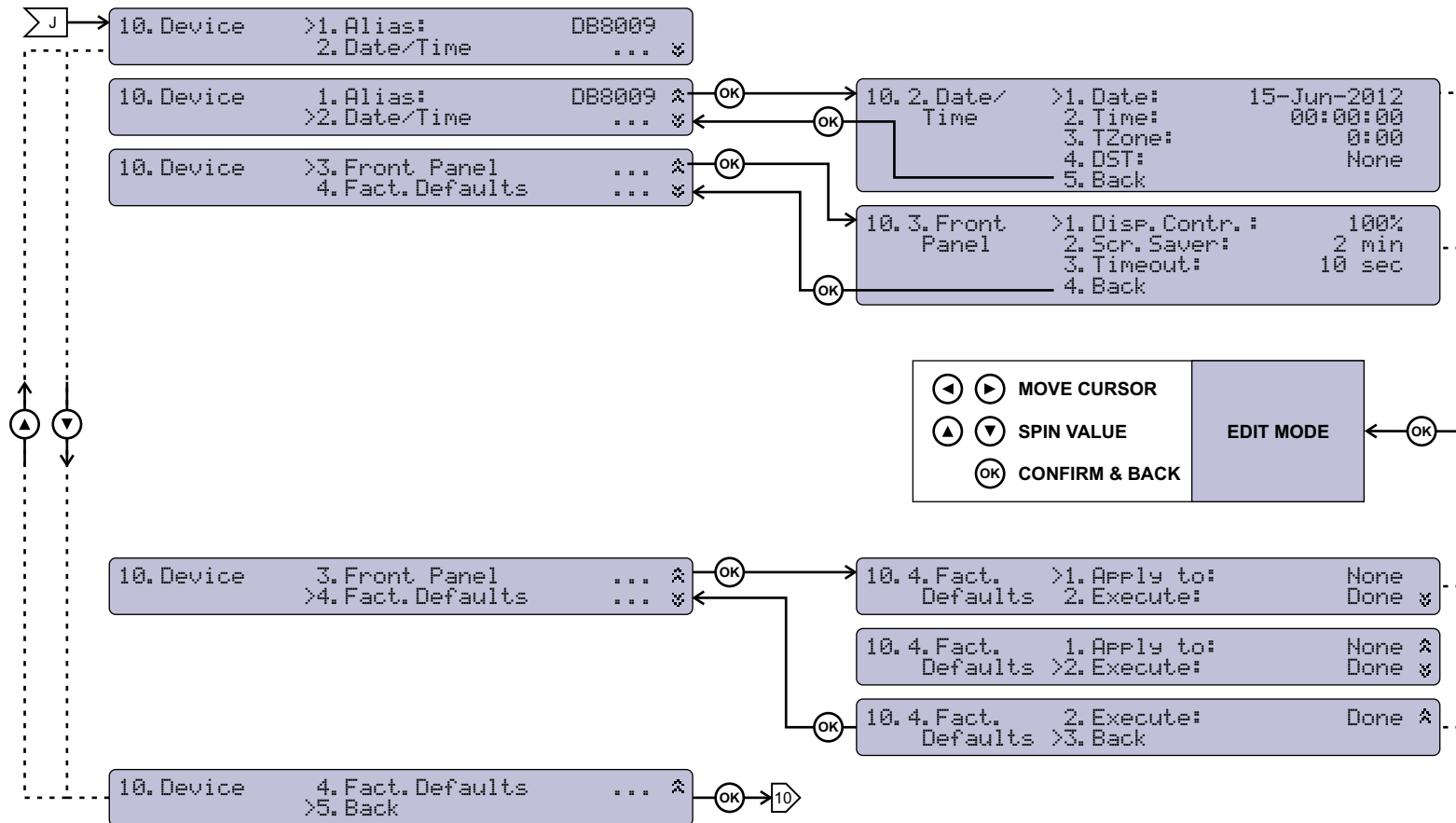

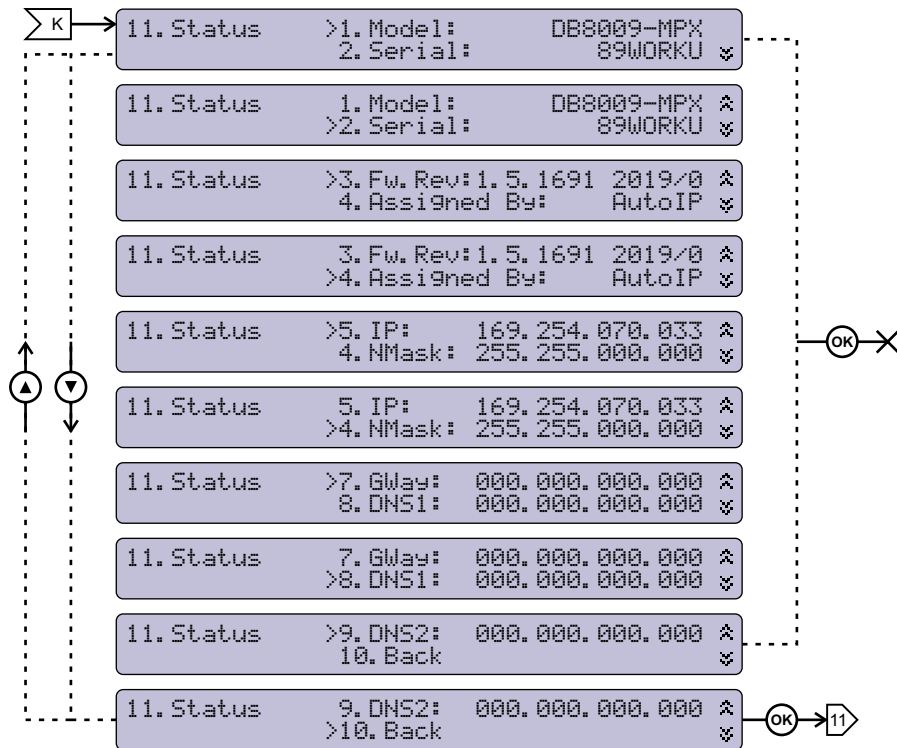

RESTORE FACTORY DEFAULTS

If an emergency recover is necessary, the DB8009-MPX can Restore Factory Defaults from its non-volatile memory. The step-by-step process can be found below:

1. Disconnect/Remove all external cables except for the Mains Power.
2. Using the keyboard, go to `10. Device > 10. 4. Factory Defaults.`
3. Press the [OK] Button and select one of the following options - `All, Keep COM, Chans.` Press [OK];
4. Press the [Down] button and then [OK] to select the `Execute` menu. Then using the [Down] button select `Yes` and press [OK].
5. The device will be returned to its factory defaults.

WARNING: When the device is returned to its Factory defaults, remote users would not be notified, and may not be able to communicate with th device.

Connecting DB8009-MPX

ANALOG AUDIO INPUTS

Using a cable ending with two standard XLR connectors, connect the analog signal source to the analog audio inputs of DB8009-MPX.

WARNING: Do not exceed the maximum input level. This may permanently damage DB8009-MPX.

DIGITAL AUDIO INPUT

Using a cable ending with a standard XLR connectors connect the AES/EBU signal source to the digital audio input of DB8009-MPX.

NOTE: As only one input can be managed by the encoder at a time, please select the preferred signal source input – either analog or digital one. Selecting the preferred input can be made via SETTINGS menu ([see “Input” on page 39](#)).

LAN PORT

In order for the normal operation of the device to be guaranteed, it is necessary the encoder to be connected to a local network or the Internet by a cable with RJ-45 connector.

Operation

DB8009-MPX is controlled through a built-in WEB Server and a standard Web browser can be used to monitor its status or to make some adjustments. To operate the device you need to know its IP Address. In case you are not aware of it, you can use the Network discovery feature at Local networks or the front panel navigational menu (Manual IP Identification).

MANUAL IP IDENTIFICATION

1. Connect the device to the local network or to the Internet by LAN cable;
2. Using the front panel navigation menu press [OK] button to enter the device Menu;
3. Using the navigation buttons find the **6. Network** – press [OK] – navigate to **6. 1. Ethernet General** – press [OK] – navigate to **3. IP**;
4. A screen containing information about the **2. DHCP Mode** and the **3. IP Address** of the device will appear.

Open a new WEB Browser and enter the device IP address in the address field then press [Enter]. A new WEB browser with DB8009-MPX's Main window will appear.

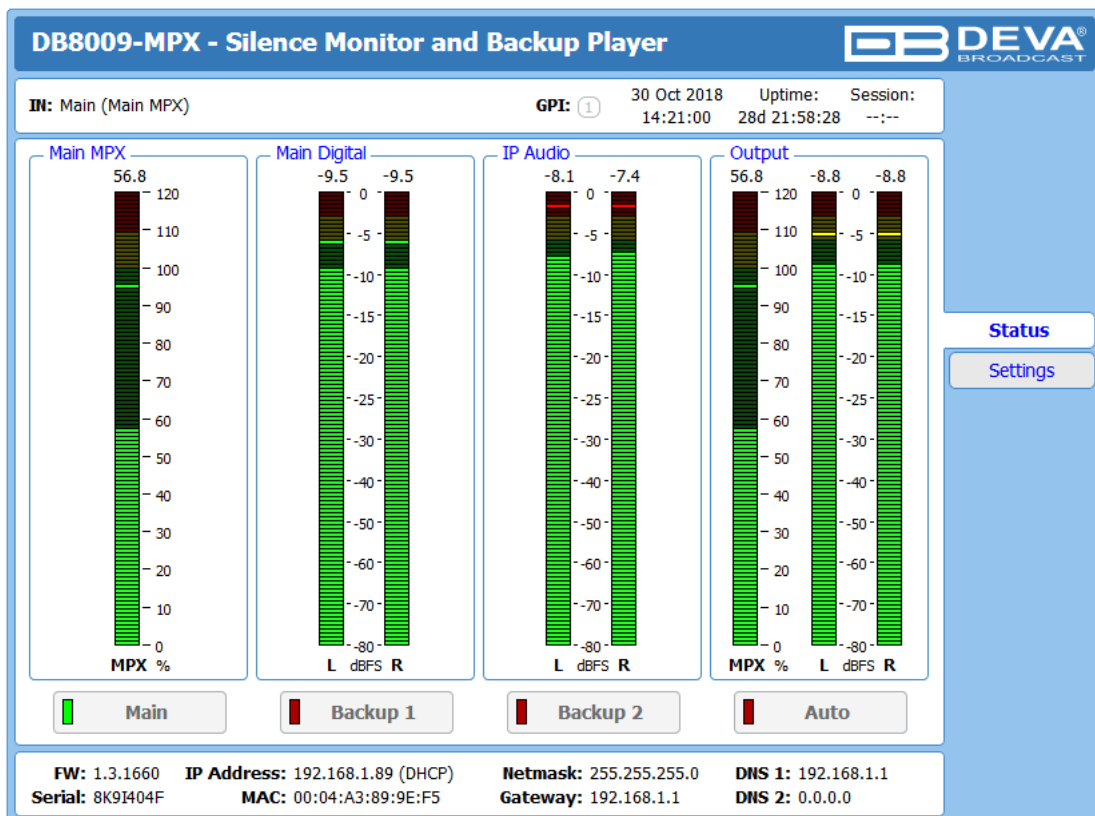

To access the device's settings press [Settings], the default values are username: *admin* and password: *pass*.

The screenshot displays the 'DB8009-MPX - Silence Monitor and Backup Player' web interface. At the top, the DEVA BROADCAST logo is visible. The main header area shows system information: 'IN: Main (Main MPX)', 'GPI: 1', the date '30 Oct 2018', and 'Uptime: 14:32:07' with a session duration of '28d 22:09:34'. Below this, there are four audio level meters: 'Main MPX' (67.6), 'Main Digital' (-9.2, -9.9), 'IP Audio' (-5.6, -5.0), and 'Output' (67.6, -7.2, -7.2). Each meter has a scale from -70 to 120. On the right side, there are 'Status' and 'Settings' buttons. The main content area features a 'Welcome!' message and a login form with 'Username:' and 'Password:' fields, and a 'Login' button.

NOTE: Due to the inability of some WEB Browsers to read the IP address format displayed on the screen of the device, the numbers included in the IP Address must be written without the leading zeros. For example: 192.168.020.068 must be written as 192.168.20.68

NETWORK DISCOVERY

1. Open Advanced sharing settings by clicking the Start button, and then on “Control Panel”. In the search box, type “network”, click “Network and Sharing Center”, and then, in the left panel click “Change advanced sharing settings”.
2. Select your current network profile.
3. Click Turn on network discovery, and then click Save changes. If you’re prompted for an administrator password or confirmation, type the password or provide confirmation.
4. To access the device open a new Explorer bar and click on Network. If you have successfully enabled the network discovery option, the device will be displayed. Double click on DB8009-MPX will open a new WEB browser with the Main window.

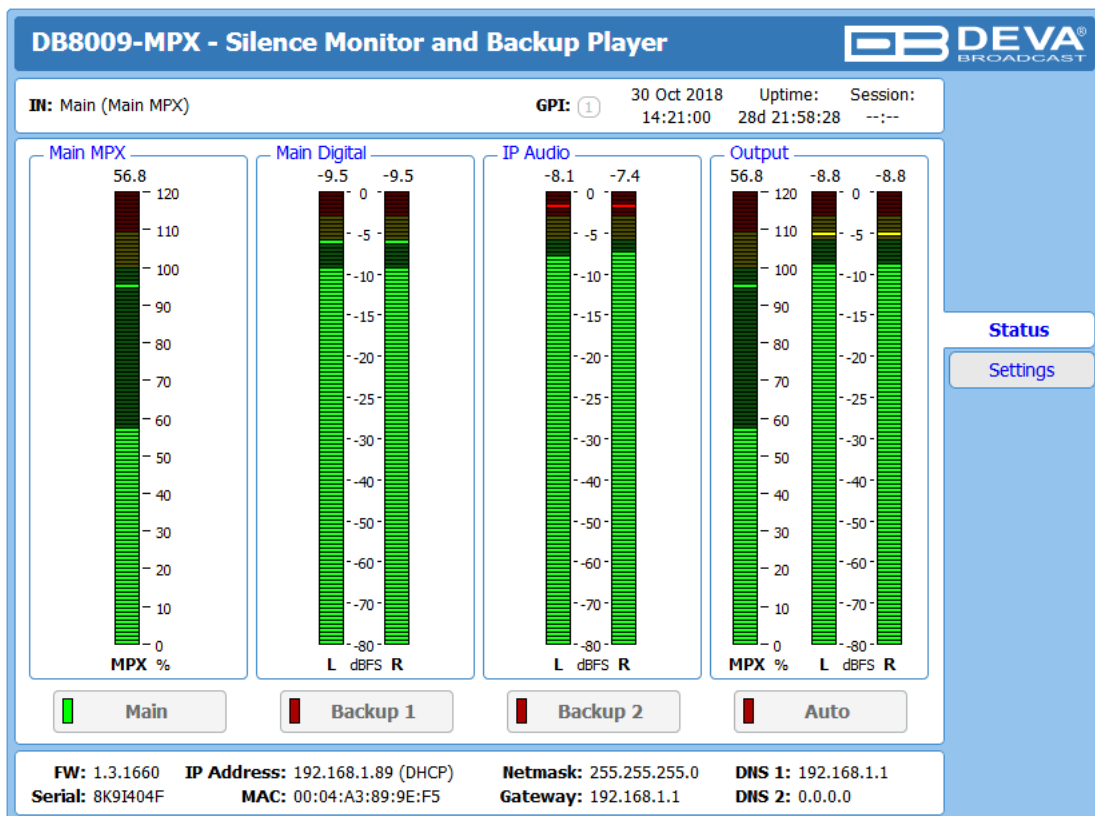

To access the device’s settings press [Settings], the default values are username: *admin* and password: *pass*.

The screenshot displays the web interface for the DB8009-MPX device. At the top, the title is "DB8009-MPX - Silence Monitor and Backup Player" with the DEVA BROADCAST logo. Below the title, there is a status bar showing "IN: Main (Main MPX)", "GPI: 1", the date "30 Oct 2018", "Uptime: 14:32:07", and "Session: 28d 22:09:34 --:--".

The main content area features four audio level meters:

- Main MPX:** Shows a level of 67.6. The scale ranges from 20 to 120.
- Main Digital:** Shows levels of -9.2 and -9.9. The scale ranges from -70 to 0.
- IP Audio:** Shows levels of -5.6 and -5.0. The scale ranges from -70 to 0.
- Output:** Shows levels of 67.6, -7.2, and -7.2. The scale ranges from -70 to 120.

On the right side, there are two buttons: "Status" and "Settings".

The central area contains a "Welcome!" message and a login form with fields for "Username:" and "Password:", and a "Login" button.

NOTE: If you have already enabled this function on your computer just open a new Explorer bar and click on Network. The device must be displayed. If not follow the instructions described above.

DB8009-MPX WEB interface menu pages

STATUS

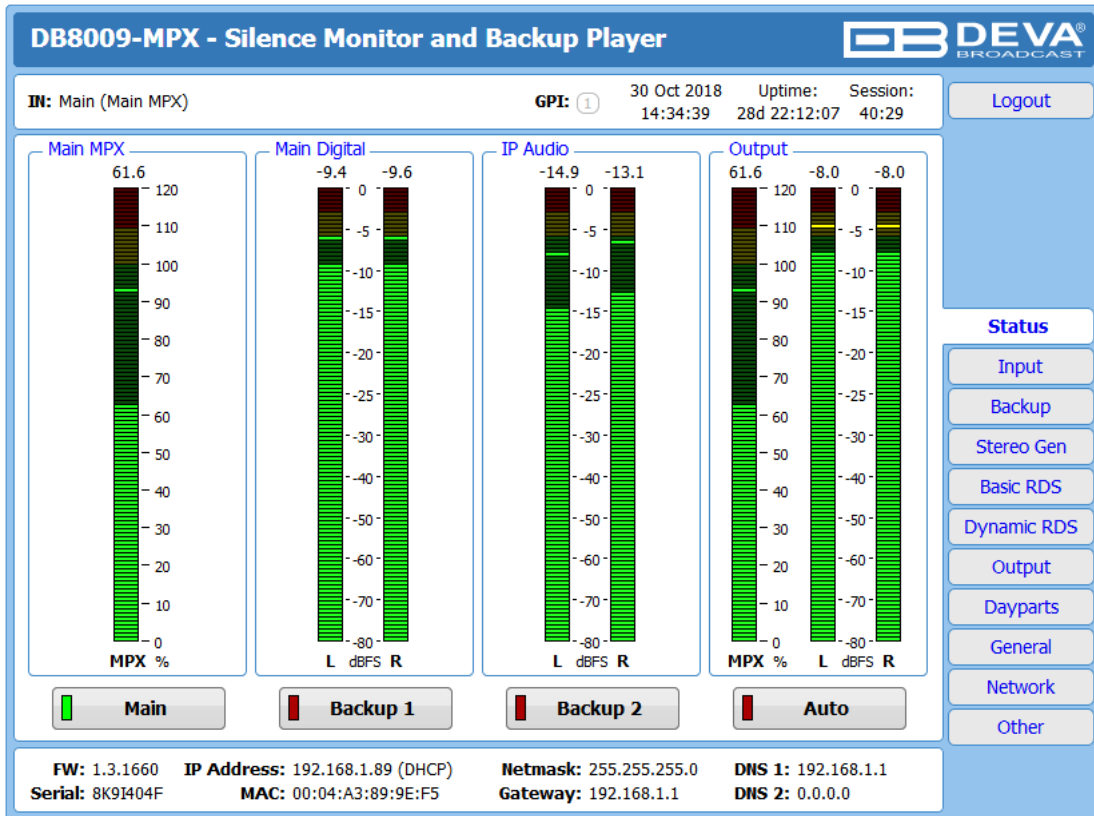

The Status screen contains information about the source levels. You can easily select the preferred audio source by using the source selection buttons.

By selecting the interactive [Auto] button, the DB8009-MPX will automatically select audio source in accordance with the applied Audio Backup Settings.

At the bottom of the control window is an information bar, gathering all the important connection parameters – Firmware Version in use, Serial Number, IP Address, and etc.

Upon change of the Web Interface screens, the main status window will resize automatically and become a constant part of each tab. Thus, allowing reading at a glance of all the mandatory parameters.

If a Backup Source is currently active, a warning message will indicate it.

INPUT

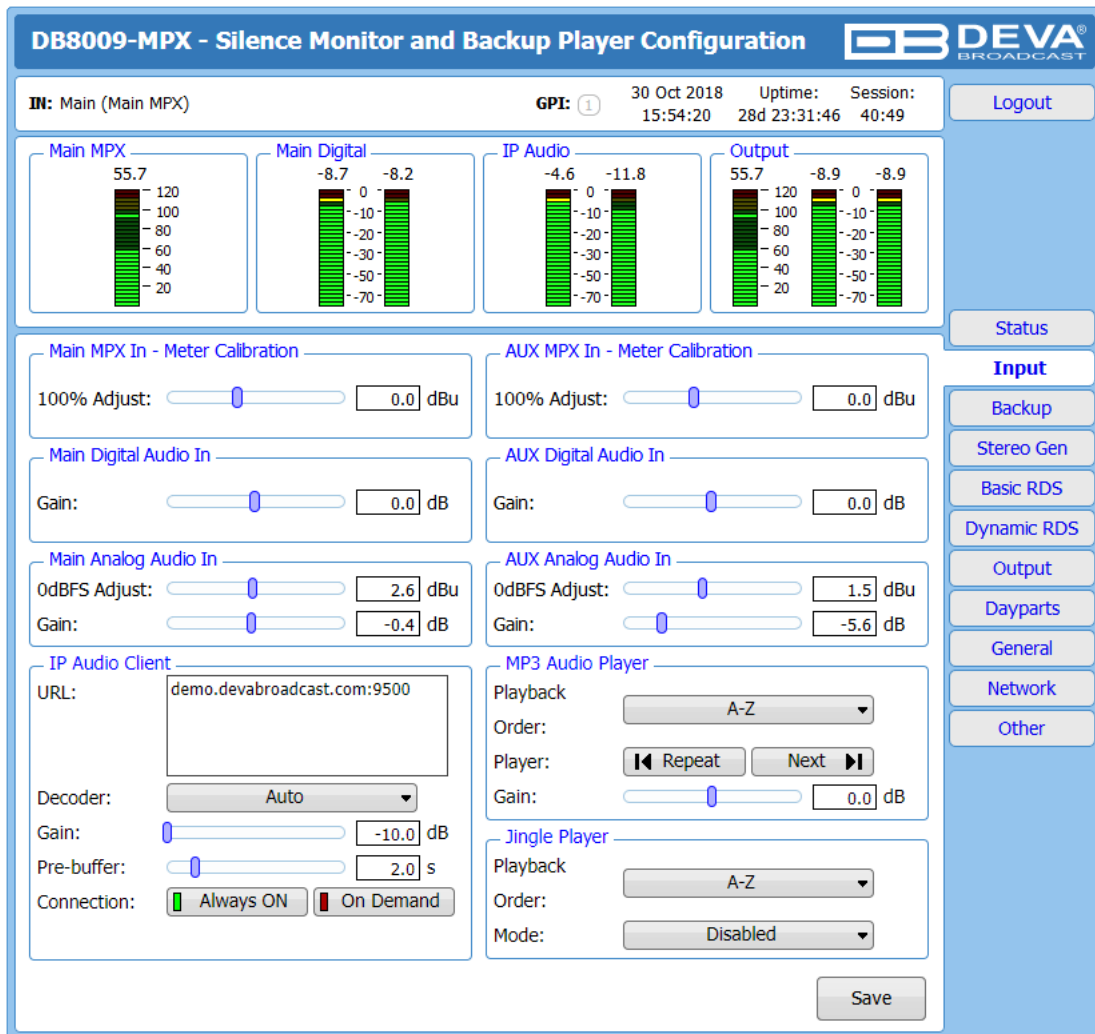

The screenshot displays the 'DB8009-MPX - Silence Monitor and Backup Player Configuration' interface. At the top, it shows system information: 'Main (Main MPX)', 'GPI: 1', '30 Oct 2018 15:54:20', 'Uptime: 28d 23:31:46', and 'Session: 40:49'. There is a 'Logout' button in the top right.

The main configuration area is divided into several sections:

- Meters:** Four level meters are shown: 'Main MPX' (55.7), 'Main Digital' (-8.7, -8.2), 'IP Audio' (-4.6, -11.8), and 'Output' (55.7, -8.9, -8.9). Each meter has a scale from -70 to 120 dB.
- Meter Calibration:** Two sections for 'Main MPX In' and 'AUX MPX In' with '100% Adjust' sliders and input boxes set to 0.0 dBu.
- Digital Audio In:** Two sections for 'Main Digital Audio In' and 'AUX Digital Audio In' with 'Gain' sliders and input boxes set to 0.0 dB.
- Analog Audio In:** Two sections for 'Main Analog Audio In' and 'AUX Analog Audio In' with '0dBFS Adjust' and 'Gain' sliders. Values are 2.6 dBu / -0.4 dB and 1.5 dBu / -5.6 dB respectively.
- IP Audio Client:** Includes a 'URL' field (demo.devabroadcast.com:9500), a 'Decoder' dropdown (Auto), a 'Gain' slider (-10.0 dB), a 'Pre-buffer' slider (2.0 s), and a 'Connection' toggle (Always ON).
- MP3 Audio Player:** Includes a 'Playback' dropdown (A-Z), an 'Order' dropdown, 'Repeat' and 'Next' buttons, and a 'Gain' slider (0.0 dB).
- Jingle Player:** Includes a 'Playback' dropdown (A-Z), an 'Order' dropdown, and a 'Mode' dropdown (Disabled).

A 'Save' button is located at the bottom right of the configuration area. On the right side of the interface, there is a vertical menu with buttons for 'Status', 'Input', 'Backup', 'Stereo Gen', 'Basic RDS', 'Dynamic RDS', 'Output', 'Dayparts', 'General', 'Network', and 'Other'.

Main and AUX MPX In Meter Calibration

Allows the user to adjust the MPX level that should be considered as 100% MPX. This setting is very important as the silence detection works based on it.

Main and AUX Digital Input

- Gain - Audio gain adjust from -10 to 10 dB. Default value is 0dB.

Main and AUX Analog Input

- 0dBFS Adjust – Allows the user to adjust the level that should be considered as 100% 0dBFS. This setting is very important as the silence detection works based on it.
- Gain - Audio gain adjust from -10 to 10 dB. Default value is 0dB.

MP3 Audio Player

The Playback Order can be changed from here. The following options are available: A-Z, Z-A, Shuffle, Playlist, and Shuffled Playlist. Information on the used and available SD card storage respectively, could also be found in this section. [Repeat] and [Next] button to navigate through the playlist if need be, are also available.

MP3 Files Upload via FTP

Through the use of a standard FTP client, you have the opportunity to update the backup content at will via any PC. The supported format is .mp3. An important requirement for the MP3 Player configuration is that all MP3 files should be stored in a folder named Audio (no sub-folders are allowed). The folder should be located in the root of the SD Card. The playlist file must be named playlist.m3u.

IP Audio Client

Set **Decoder** from the drop-down menu, and **URL** of the stream server.

- **Decoder** (+ Sample rate) – Select decoder and sample rate. It can be set to **Auto** or set manually to preferred decoder and sample rate. In Auto Mode, the DB8009-MPX will adjust decoder and sample rate, using stream supplied information. For **PCM (uncompressed)** sample rate can be **32, 44.1** or **48** kHz. For **MPEG1** the sample rate is determined automatically from the stream.
- **Pre-buffer** – The minimum amount of time in which the unit will pre-buffer before playing starts in order for problems with the connection to be prevented.
- **Connection** - Select connection type. **On Demand** will instruct IP Audio Client to establish a connection only when it is the current audio source, otherwise it will stay disconnected. This mode is useful for metered Internet connections. When set to **Always ON** the IP Audio Client will keep the connection active even when it is not the current source.

NOTE: **On Demand** does not apply if IP Audio Client is the Main backup priority. In this case it will work in **Always ON** mode.

NOTE: If Silence is detected while in **On Demand** mode, DB8009-MPX will switch to the next backup priority and will disconnect the IP Audio Client connection. It will not return to IP Audio Client again before it switches to Main first.

Jingle Player

This option is available only when the audio source is set to MP3 Audio Player. The Jingle player is designed for playing jingles (speech and music) at different intervals specified by the user. The intervals are counted by songs. From the Mode drop down menu the number of songs after which a jingle should be played is chosen. The Playback Order is also user-defined. Generally speaking, the Jingle Player allows you to make a simple radio play out.

Jingle Files Upload via FTP

Through the use of a standard FTP client, you have the opportunity to update the backup content at will via any PC. The supported format is .mp3. An important requirement is that all jingles should be stored in a folder named 'Jingles' (no subfolders are allowed). The folder should be located in the root of the SD Card. The playlist file must be named playlist.m3u. For information on how the connection between the DB8009-MPX and an FTP Client should be configured, please refer to [“Download/Upload files via FTP” on page 56](#).

How can a playlist file be made?

1. All backup audio files, and the play list must be located in a single folder named Audio.
2. Use a plain text editor to create a file named playlist.m3u.
3. The file should be stored in the same directory where the MP3 files are (folder Audio);
4. The play list should contain only the names of the files, without path. For example: Track1.mp3
5. Each track name should be on a new line.
6. The song titles should be written in the order that they will be played.

WHEN APPLYING NEW SETTINGS – In order new settings to take effect, it is necessary to press the [Save] button. Please have in mind that some of the new settings can reset DB8009-MPX.

BACKUP

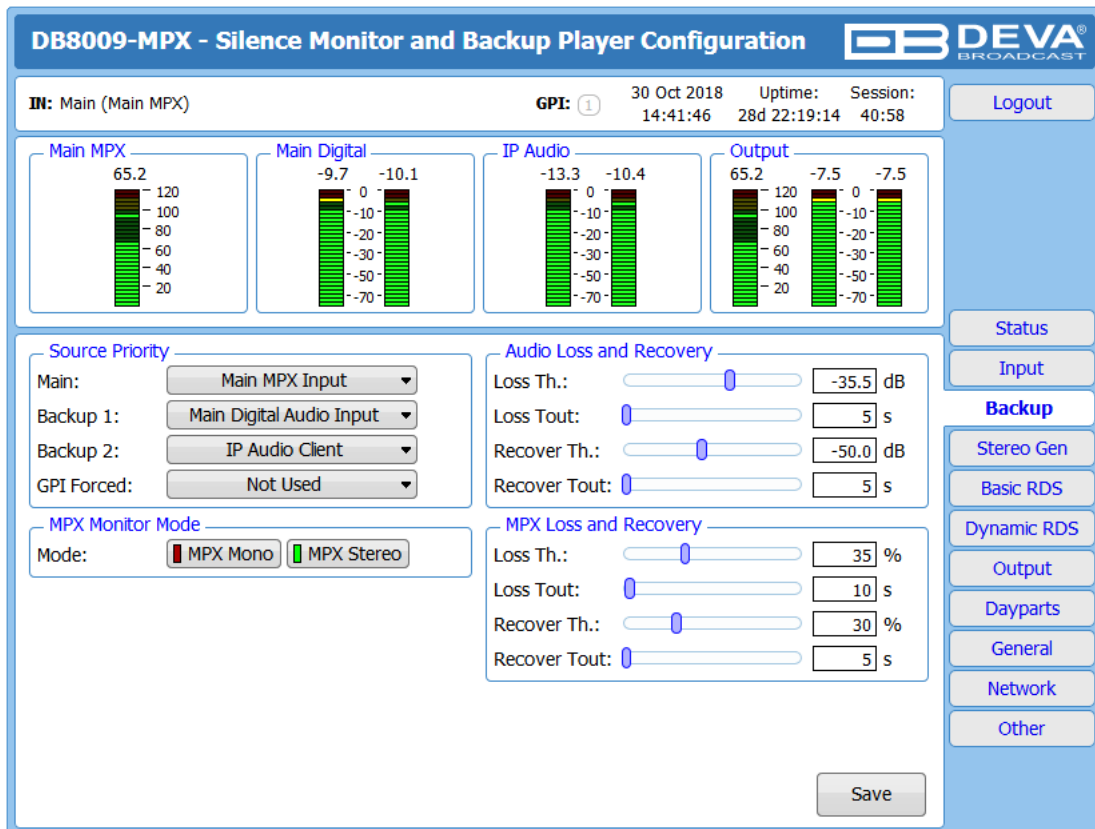

The backup sources priority is user-defined and can be set through the Source Priority section. If the audio from the main source disappears, the DB8009-MPX will automatically switch to the first backup source; if it also fails, the unit will switch to the second. Once a source with higher priority is restored, the unit will switch back to it. The GPI Forced option will force selected audio input (Main, Backup 1 or Backup 2) via GPI pin.

Audio Loss and Audio Recovery and MPX Loss and Recovery

Allow you to select the appropriate levels of loss and recovery of the audio/MPX signal. Do not forget to set the corresponding timeouts.

MPX Monitor Mode

Defines which signal will be monitored for silence and respectively switch over. The following options are available:

- MPX Mono - the DB8009-MPX will monitor the L+R sub-band only;
- MPX Stereo - the unit will monitor the L+R sub-band and the PILOT signal.

How the device works

The DB8009-MPX has two MPX (Main and AUX), two Digital (Main and AUX) and two Analog (Main and AUX) inputs.

Option 1 – Current source is MPX (Main or AUX). MPX signal is routed to MPX output. MPX signal is partially demodulated to recover L+R mono audio. This audio is then routed to Audio output.

Option 2 – Current source is Audio (IP Audio, MP3 Player, Main or AUX - Analog/Digital). The Audio signal is routed to Stereo Coder and Audio output. MPX signal is generated by Stereo Coder and routed to MPX output.

WHEN APPLYING NEW SETTINGS – In order new settings to take effect, it is necessary to press the [Save] button. Please keep in mind that some of the new settings can reset DB8009-MPX.

STEREO GENERATOR

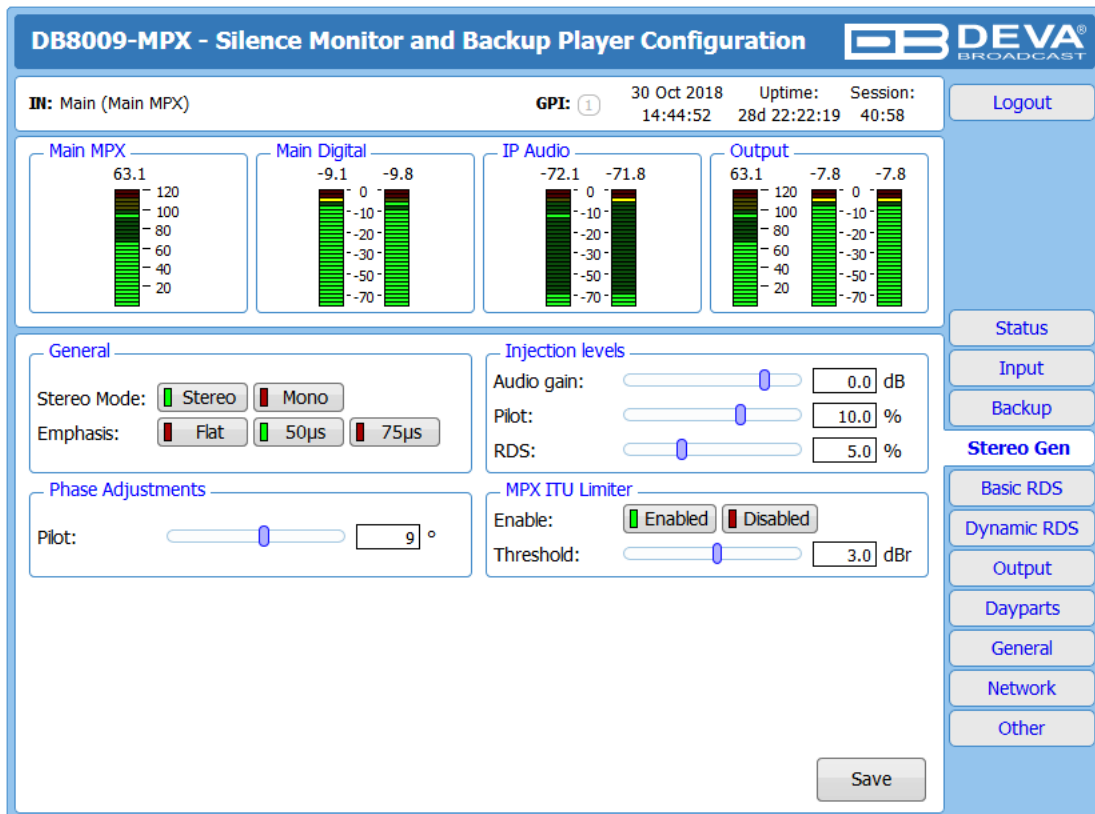

IMPORTANT NOTE: The Stereo Generator, Basic RDS and Dynamic RDS will work only when the device uses MP3 or IP Audio as audio source. When Main and AUX are used, Main or AUX MPX input will be played.

The settings of the Stereo generator are applied through this section of the Web Interface.

General

Two modes of stereo operation are available [Stereo] and [Mono]. And the Emphasis could be set to [Flat], [50µs] for Europe and [75µs] for USA.

Injection levels

Set the levels of the components included in the obtained final stereo multiplex signal.

- Audio gain - adjusts the level of the entire MPX Audio.
- Pilot - allows injection level (from 0 to 15%) of the 19 kHz pilot tone to be specified.
- RDS - sets the injection level (from 0 to 15%) of the RDS subcarrier.

Stereo Adjustment

From here you can change the phase of the PILOT tone.

MPX ITU Limiter

Limits the MPX Power as per the ITU BS412 directive. The authorities in each country have set different parameters that should be observed. It is recommended your local authorization to be checked.

WHEN APPLYING NEW SETTINGS – In order new settings to take effect, it is necessary to press the [Save] button. Please keep in mind that some of the new settings can reset DB8009-MPX.

BASIC RDS

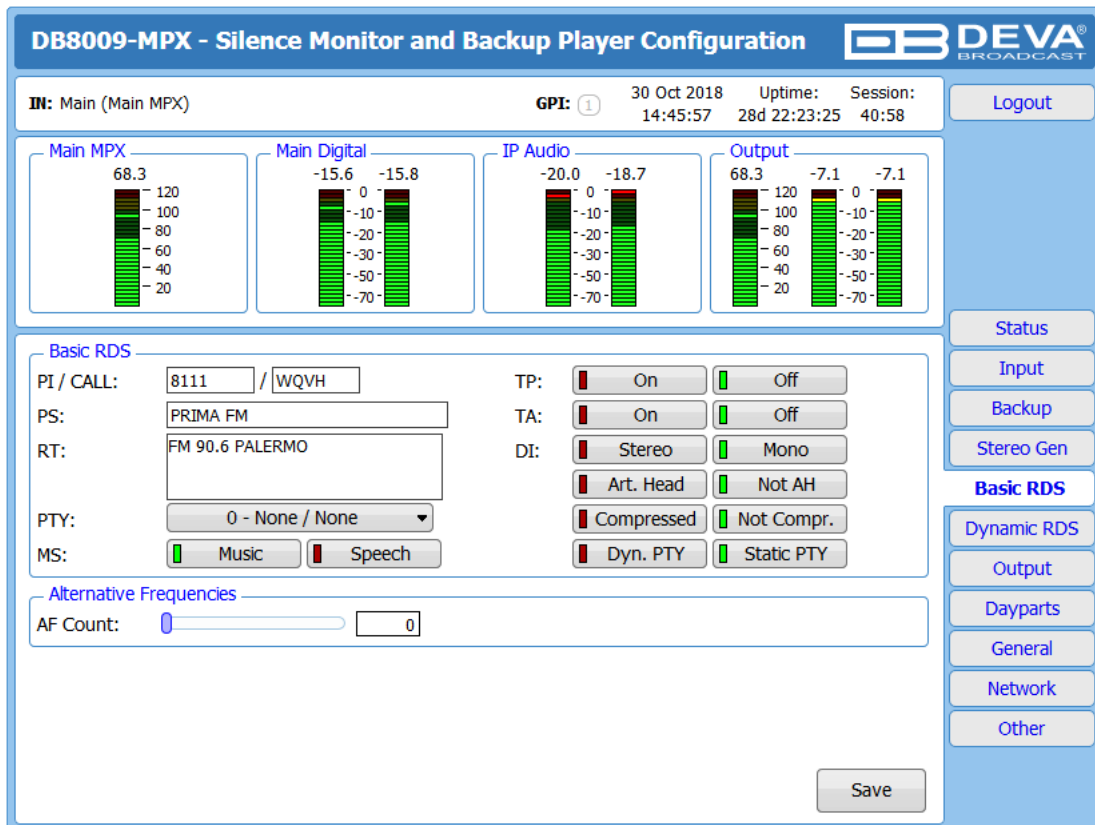

The screenshot displays the 'DB8009-MPX - Silence Monitor and Backup Player Configuration' web interface. At the top, it shows system information: 'Main (Main MPX)', 'GPI: 1', '30 Oct 2018 14:45:57', 'Uptime: 28d 22:23:25', and 'Session: 40:58'. There are four level meters: 'Main MPX' (68.3), 'Main Digital' (-15.6, -15.8), 'IP Audio' (-20.0, -18.7), and 'Output' (68.3, -7.1, -7.1). The 'Basic RDS' section includes fields for 'PI / CALL:' (8111 / WQVH), 'PS:' (PRIMA FM), and 'RT:' (FM 90.6 PALERMO). There are also dropdown menus for 'PTY:' (0 - None / None) and 'MS:' (Music, Speech). A series of toggle buttons are present for 'TP:', 'TA:', 'DI:', 'Art. Head', 'Compressed', 'Dyn. PTY', and 'Static PTY'. An 'Alternative Frequencies' section has an 'AF Count' slider set to 0. A 'Save' button is at the bottom right. A vertical sidebar on the right contains buttons for 'Logout', 'Status', 'Input', 'Backup', 'Stereo Gen', 'Basic RDS', 'Dynamic RDS', 'Output', 'Dayparts', 'General', 'Network', and 'Other'.

All basic elements of the RDS/RBDS are displayed on the screen – **PI**, **PS**, **RT**, **TA/TP** and etc. The **Alternative frequencies** are also available, represented as a list. The number of the **AF** can be set via the **AF Count Slider**. Once the needed quantity of AFs is set, the frequencies for each of them should be specified.

PI/CALL (Program Identification) – The PI code is your station’s ‘digital address’. It is a hexadecimal code that is assigned by an appropriate broadcasting authority in most countries, but in the United States the PI code is numerically calculated from the station’s call sign. We have provided a calculator utility within the DB8009-MPX. An in-depth discussion of the mathematical calculation is given in RDS/RBDS Standard. To use the PI calculator for US ‘K’ and ‘W’ call signs, simply enter call letters into the CALL box. The hexadecimal code will automatically be calculated into PI box. If the hexadecimal code for a US station is known, you may enter it under PI, and then the call sign will be calculated automatically into CALL box. When PI calculator fails to calculate PI or CALL the corresponding box will be filled with ‘----’.

PS (Program Service Name) – This is the station’s “street name” that will appear on the receiver faceplate display. The PS can be up to eight characters in length (including spaces) and can be as simple as the station’s call letters: KWOW or KWOW FM, or a slogan: NEWSTALK or LIVE 95.

RT (Radio Text) – This is a 64-character block of plain text that the listener can select for visual display on the faceplate of the radio by pressing an INFO button on the receiver. This function is not available on many automobile radios for safety reasons, which has precipitated the frowned-upon practice of scrolling the PS field instead. The Radio Text can announce song titles and performers, run special promotions or contests, or broadcast sponsors’ messages.

PTY (Program Type) – The PTY data flag identifies the station format from a pre-defined categories. Many RDS receivers are able to seek the listener’s preferred format automatically.

This means that a car radio can switch from a fading station to a stronger one that carries the same variety of music, though not the very same program, as provided by AF switching. The PTY function of RDS helps a broadcaster catch ‘transient audience’ share. The PTY code is not meant to change from song to song or to accommodate a top-of-the-hour newscast, however.

MS (Music/Speech Switch) – This flag simply indicates whether music or speech is the primary broadcast programming.

TP (Traffic Program Identification) – The TP flag identifies the station as one that routinely broadcasts traffic bulletins for motorists as part of its normal, everyday programming. When the TP flag is displayed on the receiver faceplate, the radio is searching for traffic announcements. The radio keeps track of TP stations offering this service to speed up the search-and-switch process.

TA (Traffic Announcement) – This is a temporary flag added to the RDS data stream only when a traffic bulletin is being aired. Some RDS car radios can be set to search for traffic bulletins among various TP stations while tuned to a listener’s preferred program, or even while playing a tape or CD. As soon as any TP station broadcasts a traffic bulletin, the receiver temporarily switches-over to receive it. When the bulletin is finished, the receiver switches back to the original program, tape or CD.

DI (Decoder Information) – This is one of several ‘flags’ that convey yes/no or other very basic data. This particular flag tells the receiver whether the broadcast is monaural, or is being transmitted in any of several methods of stereo or binaural broadcasting.

List of Alternative Frequencies – A network broadcaster, or one with low-power rebroadcast transmitters (translators) to fill holes in his coverage area, can include a list of all frequencies where the identical program can be heard simultaneously. The RDS receiver (particularly the upscale car radio) constantly searches for the best signal that carries the very same program. When a better signal is found, the radio re-tunes with no noticeable interruption. The principal utility of this RDS function is with European radio networks and US stations with ‘translators.’

WHEN APPLYING NEW SETTINGS – In order new settings to take effect, it is necessary to press the [Save] button. Please keep in mind that some of the new settings can reset DB8009-MPX.

DYNAMIC RDS

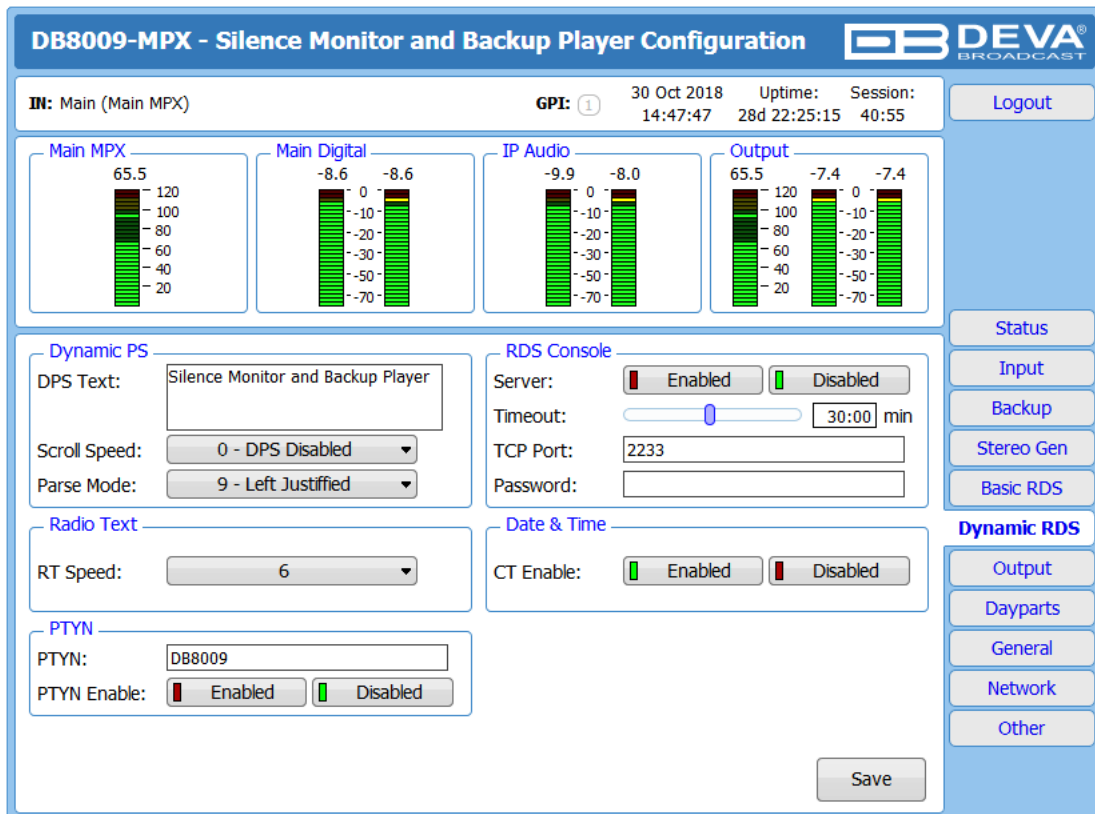

The screenshot displays the 'DB8009-MPX - Silence Monitor and Backup Player Configuration' interface. At the top, it shows the system name, DEVA logo, and session information (30 Oct 2018, 14:47:47, Uptime: 28d 22:25:15, Session: 40:55). Below this are four audio level meters: Main MPX (65.5), Main Digital (-8.6), IP Audio (-9.9), and Output (65.5). The configuration sections include:

- Dynamic PS:** DPS Text (Silence Monitor and Backup Player), Scroll Speed (0 - DPS Disabled), Parse Mode (9 - Left Justified).
- RDS Console:** Server (Enabled), Timeout (30:00 min), TCP Port (2233), Password.
- Radio Text:** RT Speed (6).
- Date & Time:** CT Enable (Enabled).
- PTYN:** PTYN (DB8009), PTYN Enable (Enabled).

 A 'Save' button is located at the bottom right of the configuration area. On the right side of the interface, there is a vertical menu with buttons for Status, Input, Backup, Stereo Gen, Basic RDS, Dynamic RDS, Output, Dayparts, General, Network, and Other.

IMPORTANT NOTE: The Stereo Generator, Basic RDS and Dynamic RDS will work only when the device uses MP3 or IP Audio as audio source. When Main and AUX are used, Main or AUX MPX input will be played.

Dynamic PS

‘marches’ the message across the display screen one character at a time. The message requires a much longer transmission time in this mode, but a glance at the radio display a few seconds still allows the driver to get the full message without missing words.

Scroll Speed – The speed of dynamic PS messaging is set here, or dynamic PS messaging can be turned off entirely. When 0 - DPS Disabled is selected, the dynamic PS message remains in the nonvolatile encoder memory, but only the 8-character default static “street name” typed into the PS field (Basic RDS) will be displayed on the receiver faceplate. Setting the speed at 1 - Slowest will result in the slowest refresh rate of the ‘block’ message, or slowest safe scrolling. 9 - Fastest is the fastest speed, but many RDS radios display gibberish at high speed settings. The display should be stable with any radio at a speed setting of 7 or lower.

Parse Mode – sets the scroll step to be used in the “block” mode message transmission, more popular as ‘grouped-word’ method. Once Parse Mode option is set, this encoder function is valid for any scrolling-PS message, whether it is entered into the static DPS register, or received as ASCII text from station automation. Very short words are sent together in groups. For example, THIS IS constitutes seven characters that can be sent as a group. The same is applicable for OF THE or NOW HERE, also. Longer words, up to and including 8 characters, are sent individually: WARNING or DOUGHNUT or BICYCLE. The device can either center words that are sent individually on the radio display or left-justify them. This will be covered along with the function of the ‘DPS Scroll Step’. Words that exceed the available 8 characters are ‘sidestepped’ through two or more consecutive displays. Examples: EMERGENC followed by MERGENCY, or SUPERMAR followed by UPERMARK and PERMARKE and ERMARKET. This method of splitting words gives a good

sense of continuity and readability. Setting Parse Mode to 1 - Scroll by 1 letter will scroll the message one character at a time, as described. Other numbers also safe-scroll the message, but at 2, 3, 4, and up to 8 characters at a time. Selecting 9 - Left Justified will parse, as described, but text will be left-justified rather than centered on the display. 2 through 8 may be useful in some special RDS applications, but 0 and 1 are the primary Parse Mode selections. To recap: 0 - Centered will enable the more-popular, centered-auto-parsed block mode and 1 - Scroll by 1 letter the Dynamic PS, letter-by-letter option.

Radio Text

RT Speed – The Radio Text update rate is programmed by setting RT Speed = n , with n a number between 1 and 9, corresponding to a refresh rate between slow and fast, respectively. Keeping the throughput tradeoff in mind, unless Radio Text is being used for contests or for other quasidynamic activities, it is best to use a lower number. A rate of 1, 2 or 3 will make little difference in the speed of other RDS functions. Radio Text can be turned off entirely by setting: RT Speed=0. A zero value in this field turns the Radio Text message off, but does not delete any saved message from memory. The RT (Radio Text) is set in Basic RDS tab.

PTYN (Program Type Name) Settings

PTYN – Program Type Name is transmitted as 8-bit characters. PTYN must only be used to enhance Program Type information and it must not be used for sequential information.

PTYN Enable – [Enable] or [Disable] type 10A Group Transmission. This group allows further description of the current Program Type.

Date & Time Settings

CT Enable – [Enable] or [Disable] type 4A Group Transmission.

Console Settings

Server – [Enable] or [Disable] the RDS Console

Timeout – allows session timeout to be specified. Upon expiration of the time set the connection will be disabled.

TCP Port – a field where TCP port of the RDS console is to be entered. This console is used to edit RDS settings in real time. Default value is 2233.

Password – Password for the RDS console. These are the first symbols that must be sent to authenticate to the RDS console, otherwise the connection will be cancelled. If left blank NO security is used. Default value is blank (empty).

WHEN APPLYING NEW SETTINGS – In order new settings to take effect, it is necessary to press the [Save] button. Please keep in mind that some of the new settings can reset DB8009-MPX.

HOW TO CONNECT TO THE RDS CONSOLE

The RDS console is used to edit the RDS settings in real time. It can be used with an automation software or a terminal program.

To use the console, follow the steps listed below:

1. Connect to the TCP port of the RDS console with a terminal program or an automation software;
2. A welcome message HELLO will be received if proper connection is established;
3. If password is needed, the following message will appear PASS?;
4. Proceed with entering the commands.

RDS Console syntax

```
HELLO  
pass↵  
PASSOK  
PI=1234↵  
OK  
PI?↵  
1234  
OK  
TP=3↵  
NO
```

Depicted above is a sample RDS console conversation when a password is not set. The red text represents the user input and the black text - the console's responses. The ↵ symbol represent the Enter key on the keyboard.

- First row – is the welcome message from the RDS console. Next the user types in the password (in this case 'pass'), followed by Enter.
- Third row is the response meaning that the password is accepted and the user may proceed with commands.
- Fourth row is a 'set' command. These types of commands are used to set new value to RDS parameters. In the example above 'PI' is the Program Identification command, '=' (equal sign) means set new value and '1234' is the new value. The Enter key represents command's end and signals the RDS console to execute the command.
- Fifth row is a positive response from the RDS console. It means the command is accepted and executed successfully.
- Sixth row is a 'get' command. These types of commands are used to return the current value of RDS parameters. In the example above 'PI' is the Program Identification command, '?' (question mark) means return PI's value. The RDS console responds with the current value (in this case '1234') and positive response on the next row.
- Ninth row is again a 'set' command. In this case: Set Traffic Program to 3. The response is negative because the parameter TP can only have value 0 or 1.

List of available RDS console commands and their responses

PARAMETER	COMMAND	DATA ENTRY
INIT	INIT	Applies the default settings.
Program Identification	PI	4 digit HEX number (station "digital address")
Program Service	PS	8 (max) ASCII characters (station "street name")
Dynamic PS	DPS	64 (max) ASCII characters (for messaging in PS field)
Dynamic PS Speed	DPSS	0 to 9 (0 = Off, 1 = slow, 9 = fastest)
Dynamic PS Method	PARSE	0 through 9 (0 = parsed, centered; 1-8 = Safe Scrolling; 9 = parsed, left)
PTYN	PTYN	Sets Program Type Name
Program Type	PTY	1 or 2 digit number (describes station format)
Traffic Program	TP	0 or 1 (0 = no, 1 = yes)
Traffic Alert	TA	0 or 1 (0 = flag off, 1 = flag on)
Alternative frequencies	AF	0 to 204 (0 = blank; 1 to 204 = "channel" in 100 kHz increments, 87.6 MHz to 107.9 MHz)
Decoder Information	DI	1 digit HEX number
Music/Speech	MS	0 or 1 (0 = speech-only, 1 = music)
Radio Text	TEXT	64 (max) ASCII characters
Radio Text Speed	DRTS	0 to 9 (0 = RadioText off; 1 to 9 = update rate, slow to fast)
Command Echo	ECHO	0 or 1 (0 = echo off, 1 = echo on)
CT group 4A control	CTON	0 (disables) or 1 (enables) type 4A Group Transmission
PTYN group 10A control	PTYNON	0 (disables) or 1 (enables) type 10A Group Transmission
AF count	AFCOUNT	Sets the numbers of AFs transmitted.

SPECIAL COMMAND	MEANING
=	Set parameter value. Following a parameter command sets new value to that parameter; e.g.: PI=1234
?	Get parameter value. Following a parameter command returns status of encoder memory for that parameter; e.g.: AF3?
??	Returns all data in encoder memory.
INIT	Initializes the encoder to all factory defaults.

RESPONSE	MEANING
HELLO	Welcome message when connection to the console is established. If security is enabled proceed with entering the password. Otherwise proceed with commands.
PASS?	Password request. Will appear if such os set.
PASSOK	Password accepted, may proceed with commands.
PASSFAIL	Wrong password. Connection is dropped immediately
OK	Command received by encoder properly formatted and understood.
NO	Command properly formatted but data not understood.
BYE	Console has been inactive for more than 30 minutes and the connection will be dropped. User needs to connect again to enter more commands.
(NO RESPONSE)	Data sent is ignored by DB8009-MPX.

OUTPUT

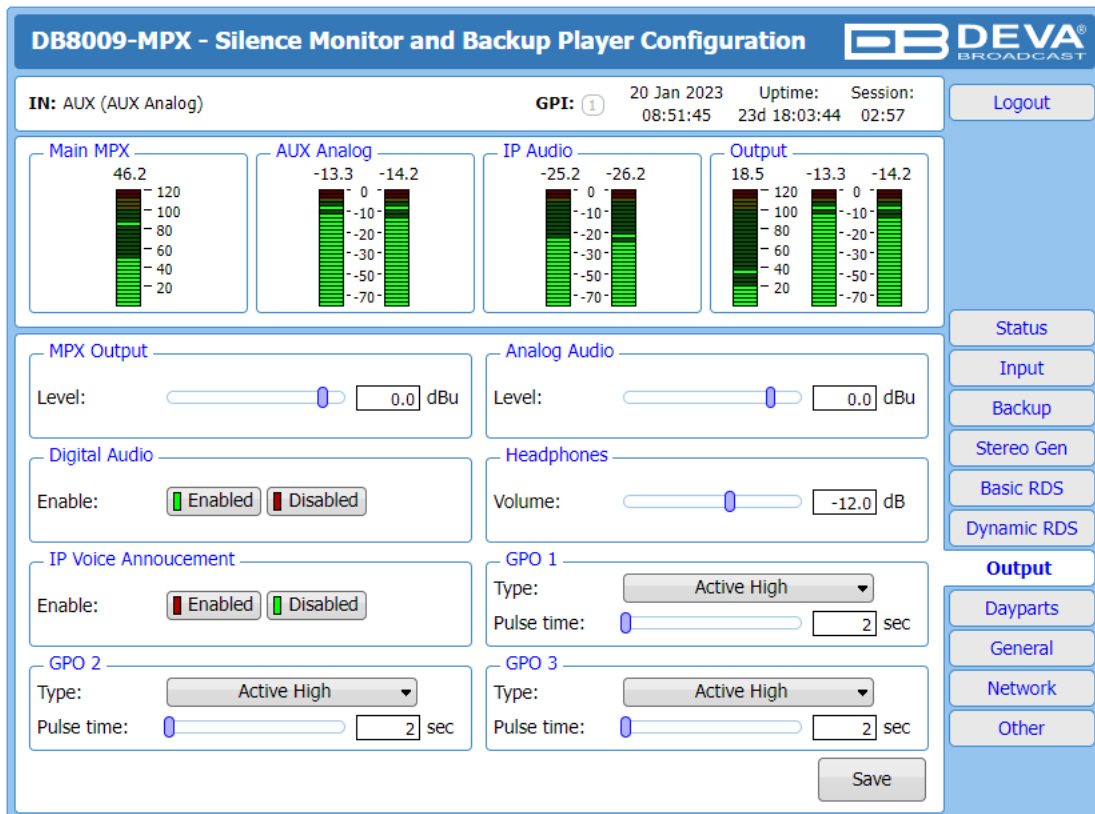

MPX Output

- select output level of the MPX signal.

Analog Audio

- set the level of the Analog Audio output (in dBu).

Digital Audio

- enable or disable the Digital Audio output.

Headphones

- set the level of the Headphones. Only the selected Silence detection audio will be heard through the headphones.

IP Voice Announcement

- Enables or disables the IP Voice Announcement option. By default and to ease the set-up process the option is enabled. Once the set-up process is completed, it is recommended the option to be disabled. Otherwise, the IP Voice Announcement will continue to be played.

WHEN APPLYING NEW SETTINGS – In order new settings to take effect, it is necessary to press the [Save] button. Please keep in mind that some of the new settings can reset DB8009-MPX.

DAYPARTS

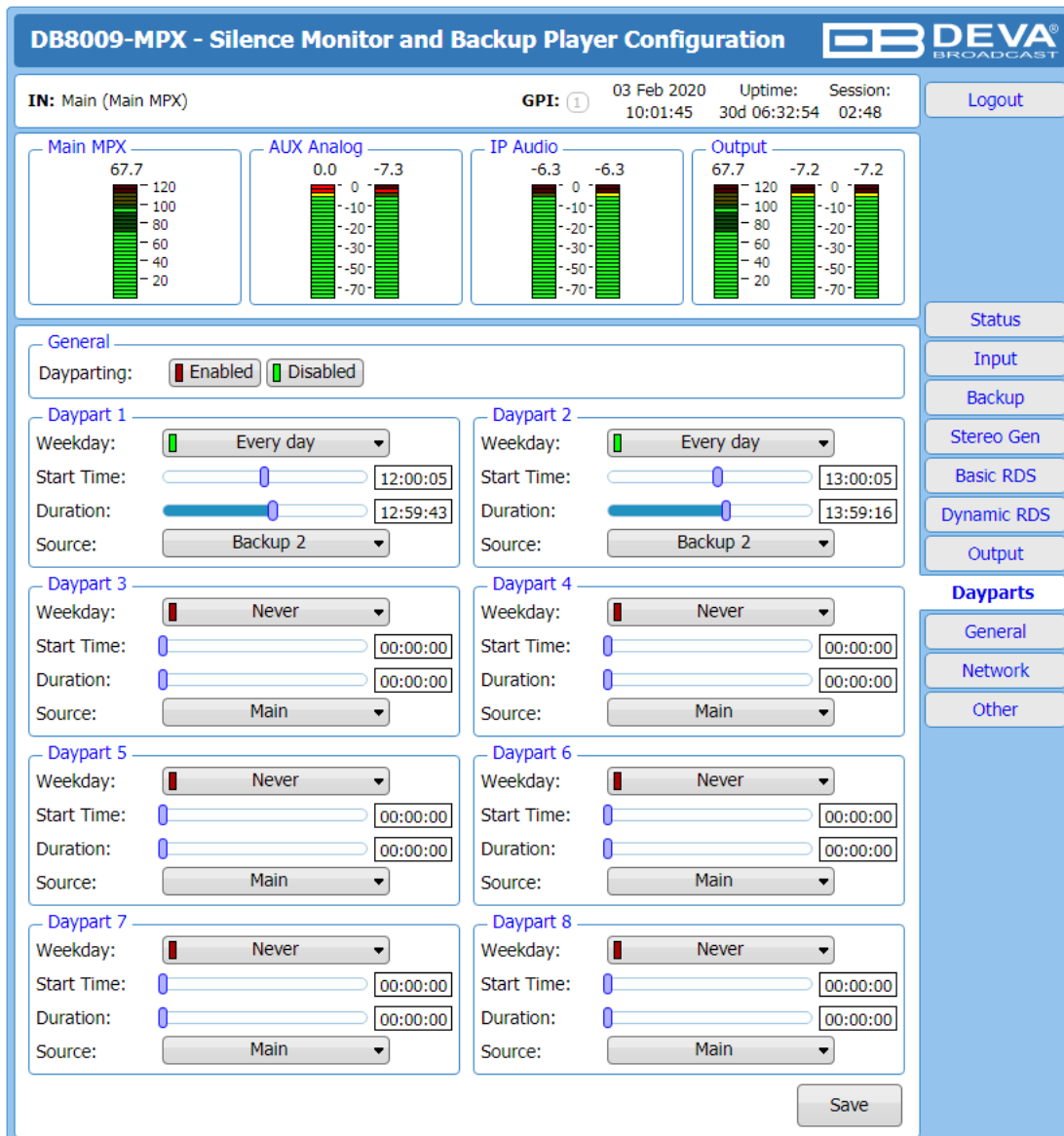

Dayparting is the practice of dividing the day into several parts, during which a different type of audio preset to be used for the audio processing. This function will allow a processing pattern based on the radio's timetable to be made.

Generally enable the Dayparts function in order to use it. Please bear in mind that if the option is generally disabled the function will not be used, nevertheless the applied settings in sections Daypart 1 to Daypart 8.

There are nine positions at your disposal that can be set. The settings to be applied for each of them are identical:

1. Select Daypart trigger day form the drop-down menu. It can be an exact date, a day of the week or every day;
2. Set the Start Time and Duration;
3. To finalize the setup, select the preset that should be used during this time period.

Repeat the same procedure for each of the positions that should be used.

NOTE: It is recommended the unused dayparts to be set to Never. Also, please note that if the Weekday is set to Never the relative daypart will not be used.

WHEN APPLYING NEW SETTINGS – In order new settings to take effect, it is necessary to press the [Save] button. Please keep in mind that some of the new settings can reset DB8009-MPX.

GENERAL

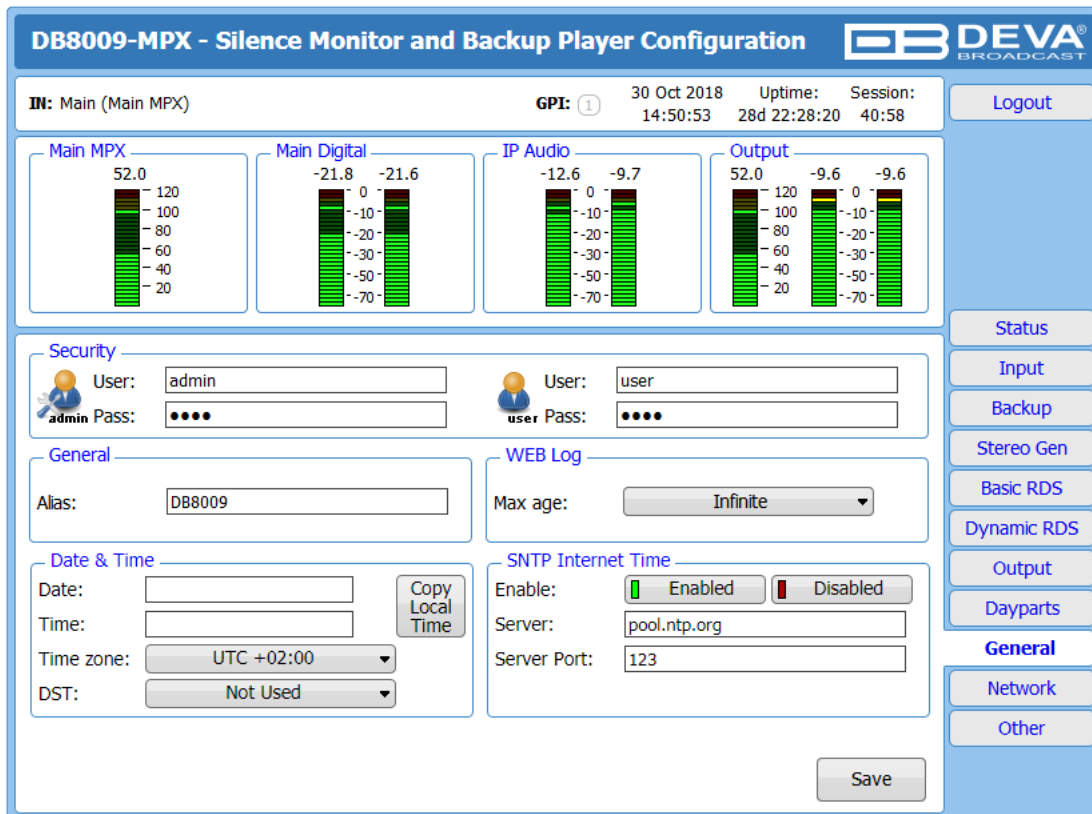

The screenshot displays the 'DB8009-MPX - Silence Monitor and Backup Player Configuration' web interface. At the top, it shows the device name 'DB8009-MPX', the user 'Main (Main MPX)', and system information including the date '30 Oct 2018', uptime '14:50:53', and session duration '28d 22:28:20'. There are four level meters: 'Main MPX' (52.0), 'Main Digital' (-21.8, -21.6), 'IP Audio' (-12.6, -9.7), and 'Output' (52.0, -9.6, -9.6). The 'Security' section includes login fields for 'admin' and 'user'. The 'General' section has an 'Alias' field set to 'DB8009'. The 'WEB Log' section has a 'Max age' dropdown set to 'Infinite'. The 'Date & Time' section includes fields for Date, Time, Time zone (UTC +02:00), and DST (Not Used), along with a 'Copy Local Time' button. The 'SNTP Internet Time' section has an 'Enable' checkbox checked, a 'Server' field set to 'pool.ntp.org', and a 'Server Port' field set to '123'. A 'Save' button is at the bottom right. A sidebar on the right contains navigation buttons: Logout, Status, Input, Backup, Stereo Gen, Basic RDS, Dynamic RDS, Output, Dayparts, General (selected), Network, and Other.

DB8009-MPX provides you with protected access to the device settings. You can choose between two types of log in.

- As an ADMINISTRATOR – It will give you full control over the device’s settings;
- As a USER – that will allow you to just monitor the device, while all the settings remain locked.

In order for the security of DB8009-MPX to be enhanced, new username and password could be set from the Security section.

By choice, you can change the name of the device (General section). Later on, it will be used as a title name on all WEB pages. Customizing the name will make the device more recognizable.

WEB Log – the maximum storage time of the log files is chosen from here. Log files older than the specified will be permanently deleted.

Date & Time – used for manually determining the current date and time. [Copy Local Time] button will set the Date & Time to correspond to that of your computer.

SNTP Internet Time – Synchronizes automatically DB8009-MPX’s clock time to a millisecond with the Internet time server. Enable this function in order to use it (Specifying the server closest to your location will improve the accuracy).

WHEN APPLYING NEW SETTINGS – In order new settings to take effect, it is necessary to press the [Save] button. Please keep in mind that some of the new settings can reset DB8009-MPX.

NETWORK

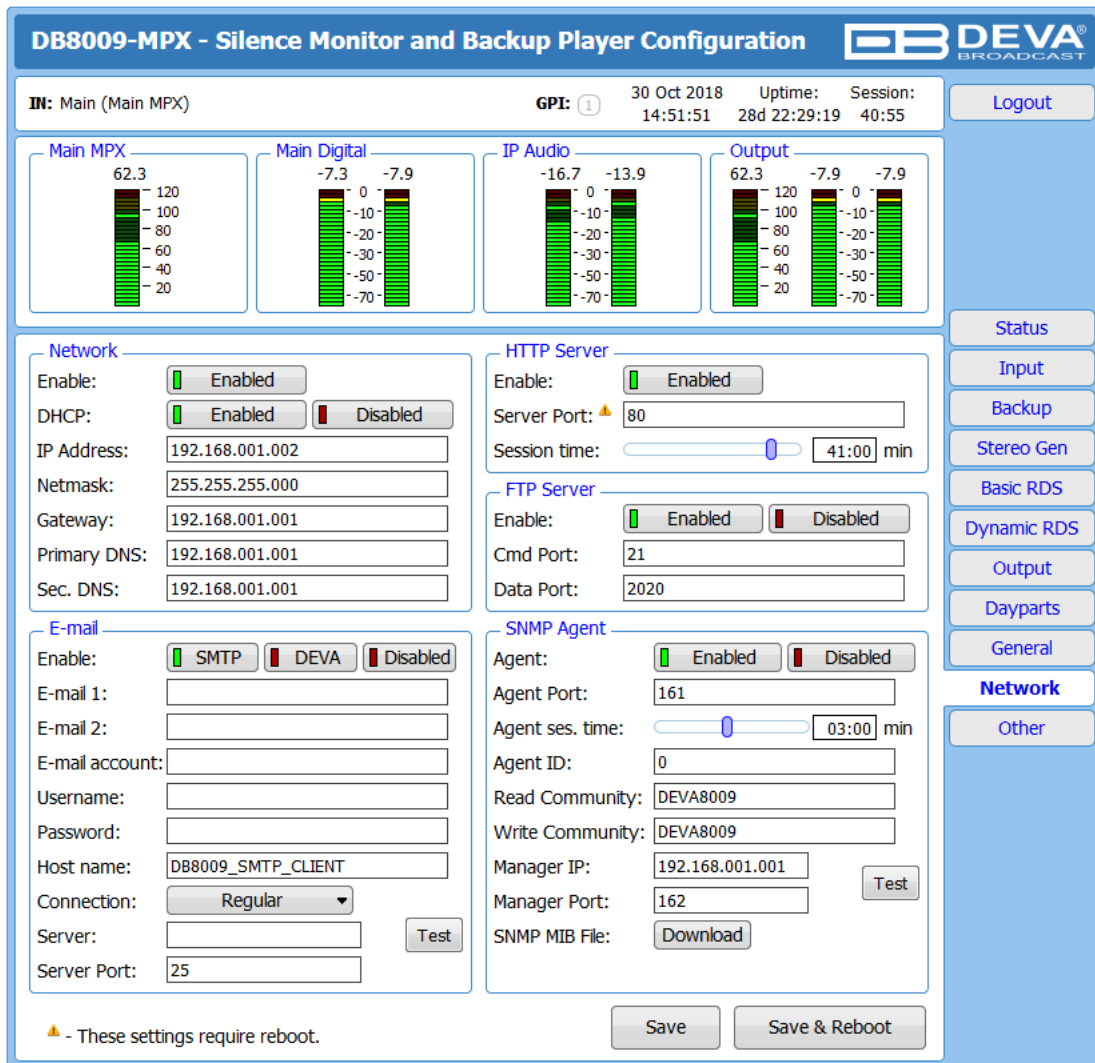

The screenshot displays the configuration page for DB8009-MPX, titled "DB8009-MPX - Silence Monitor and Backup Player Configuration". The interface includes several monitoring graphs at the top: Main MPX (62.3), Main Digital (-7.3, -7.9), IP Audio (-16.7, -13.9), and Output (62.3, -7.9, -7.9). Below these are configuration sections for Network, HTTP Server, FTP Server, E-mail, and SNMP Agent. The Network section shows DHCP enabled and static IP settings. The HTTP and FTP servers are also enabled. The E-mail section has SMTP selected. The SNMP Agent is enabled with a 3-minute session time. A warning icon indicates that some settings require a reboot. Buttons for "Save" and "Save & Reboot" are at the bottom.

Network

The network addresses could be set manually (static IP) or automatically via a DHCP Server. To set static IP, Netmask, Gateway and DNS addresses, the DHCP should be disabled. In order for the built-in DHCP client to be activated, the function should be enabled. When the DHCP client is activated, all assigned values will be shown in the relevant fields on the "Status Screen". If due to any reason, the DHCP procedure cannot be completed, DB8009-MPX will use Auto IP and will generate an IP Address.

E-mail

Enter the desired alarm recipients in E-mail 1 and/or E-mail 2 fields. Fill in your e-mail account settings: Sender, Username and Password, Server, Server Port and Connection Type. If you experience difficulties in the set-up, or would like to use DEVA account for sending of alarm email notifications, press the [DEVA] button option, and complete the recipient emails (E-mail 1 and E-mail 2) only. The other fields must be left blank, otherwise the email notification option will not be working. Even though using the DEVA account eases the set-up process, we recommend user account to be used for sending of email notifications, and the DEVA account for test purposes. When using DEVA account, please note that the stable 24/7 connection depends on the mail service provider and cannot be guaranteed. We recommend you to use the [Test] button and generate a test e-mail, which upon success will be delivered to the specified E-mail 1 and/or E-mail 2. Example of Test E-mail Message:

DB8009 Test Message.
Please do not reply to this e-mail.

HTTP Server

Enable/Disable the HTTP Server. Specify the Server Port and Session Timeout.

FTP Server

Enable/Disable the FTP Server. Specify the Command and Data Ports to be used. For information on how the connection between the DB8009 and an FTP Client should be configured, please refer to [“Download/Upload files via FTP” on page 56](#).

SNMP Agent

Specify Agent ID, Agent Port, Read/Write Communities, Manager IP, Manager Port and Agent Session Time.

Agent – enables/disables SNMP Agent.

Agent ID – is used for identification of the device among others, when an SNMP notification is being sent. Once all needed settings are applied, use the Test button to generate a test notification, which upon success will be received by the SNMP Manager. Press the [Download] button to download the latest available DB8009-MPX SNMP MIB file.

NOTE: The MIB file may vary from one firmware revision to another. Downloading this file from the device, guarantees that you have the proper MIB file.

WHEN APPLYING NEW SETTINGS – In order new settings to take effect, it is necessary to press the [Save] button. Please keep in mind that some of the new settings can reset DB8009-MPX.

OTHER

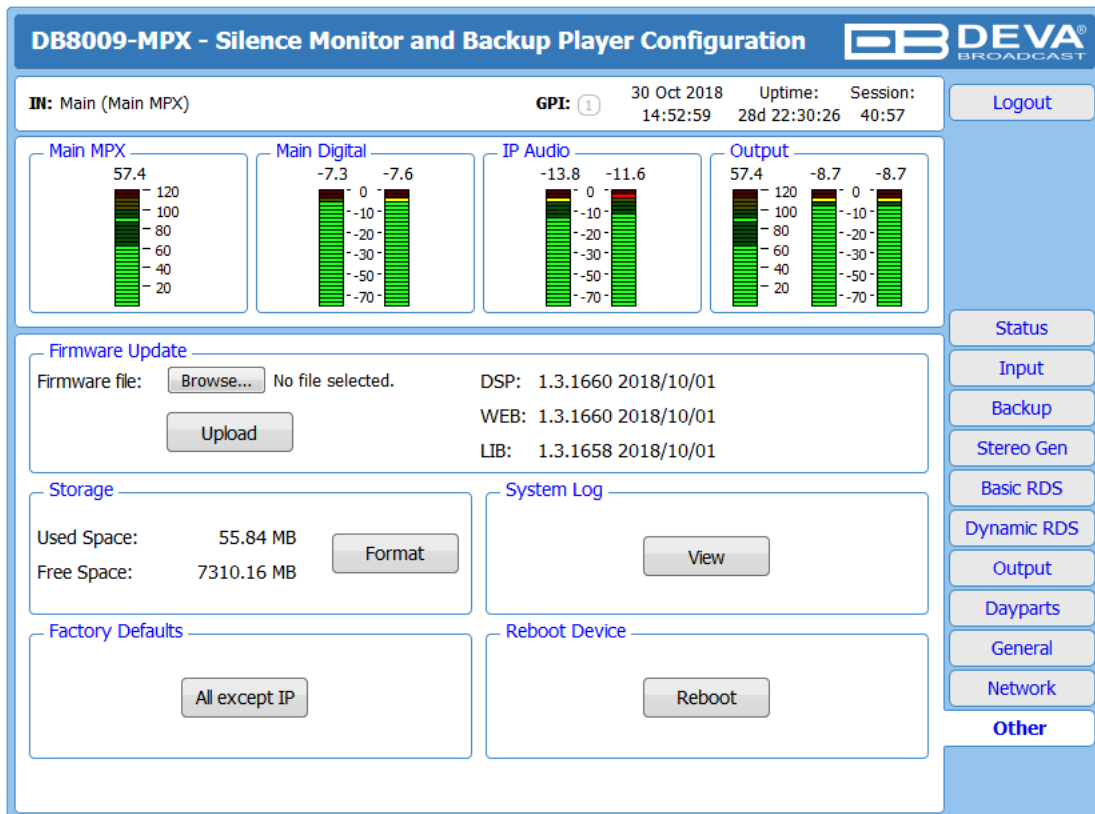

The screenshot displays the 'DB8009-MPX - Silence Monitor and Backup Player Configuration' web interface. At the top, it shows the DEVA BROADCAST logo and system information: 'Main (Main MPX)', 'GPI: 1', '30 Oct 2018 14:52:59', 'Uptime: 28d 22:30:26', and 'Session: 40:57'. There is a 'Logout' button in the top right.

The main content area is divided into several sections:

- Monitoring:** Four level meters are shown: 'Main MPX' (57.4), 'Main Digital' (-7.3, -7.6), 'IP Audio' (-13.8, -11.6), and 'Output' (57.4, -8.7, -8.7). Each meter has a scale from -70 to 120.
- Firmware Update:** A section for updating the device firmware. It includes a 'Browse...' button for selecting a file, an 'Upload' button, and version information for DSP (1.3.1660 2018/10/01), WEB (1.3.1660 2018/10/01), and LIB (1.3.1658 2018/10/01).
- Storage:** Shows 'Used Space: 55.84 MB' and 'Free Space: 7310.16 MB'. A 'Format' button is available.
- System Log:** A 'View' button to access the system log.
- Factory Defaults:** An 'All except IP' button to restore factory settings.
- Reboot Device:** A 'Reboot' button to restart the device.

On the right side of the interface, there is a vertical menu with buttons for: Status, Input, Backup, Stereo Gen, Basic RDS, Dynamic RDS, Output, Dayparts, General, Network, and Other (highlighted in blue).

Firmware Update

To update the device firmware, select the new firmware file. After having pressed the [Upload] button, a dialog window will appear. Confirm the firmware update and wait for the process to complete.

Storage

Information about the device storage space is found in this section. The internal storage could be deleted by pressing the [Format] button.

Factory Defaults

To restore DB8009-MPX to its Factory Defaults press the [All except IP] button. A new window will appear - confirm that you want to restore the factory defaults and wait for the process to be completed. On completion of the process, the settings should have the proper default values, except for the Network settings (IP Address) - they will be preserved.

NOTE: When the device is returned to its factory defaults, the DB8009-MPX will automatically use MP3 as current audio source. The device will return to its main audio source once it is restored.

Reboot

To start Rebooting of DB8009-MPX, press the [Reboot] button. A dialog warning window will appear. Confirm that you want to reboot the device and wait for the process to be completed.

System Log

By pressing the [View] button, all recorded in the system log information will be depicted on the screen. Pressing the [Clear] button will delete all recorded system log information. [Reload] will reload the data.

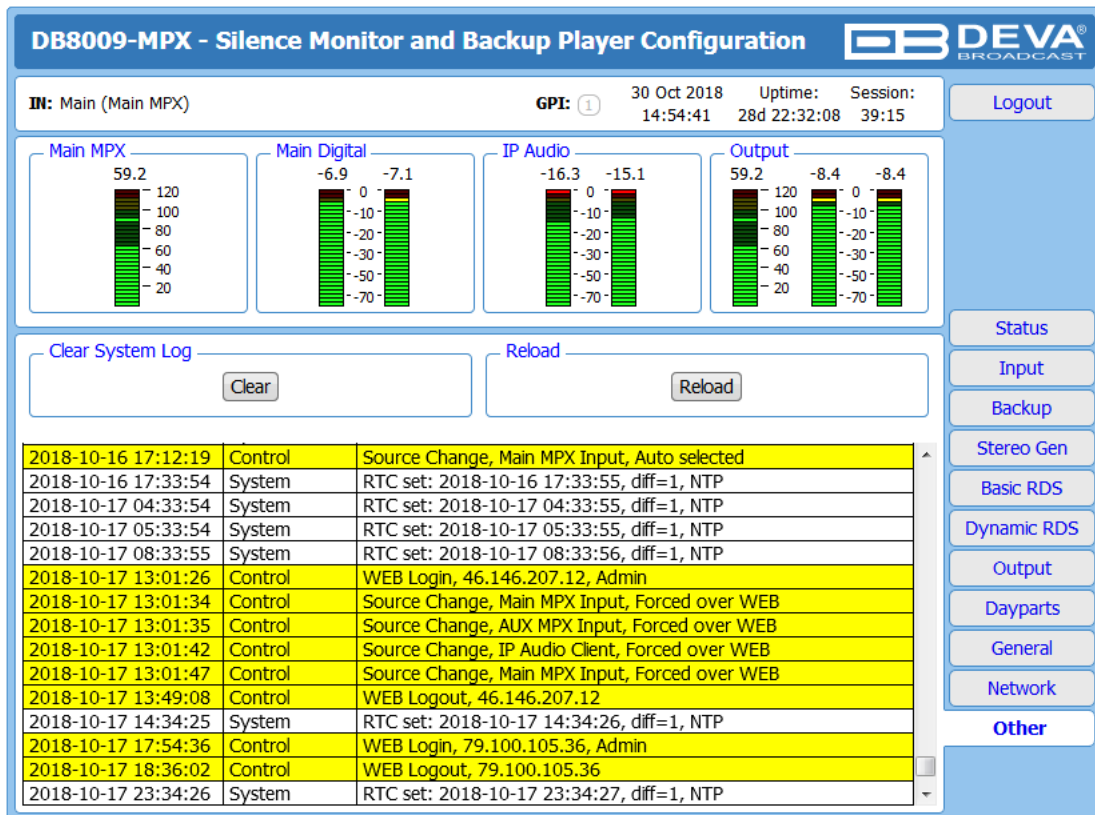

The screenshot displays the 'DB8009-MPX - Silence Monitor and Backup Player Configuration' interface. At the top, it shows the system name and DEVA logo. Below this, there's a status bar with 'IN: Main (Main MPX)', 'GPI: 1', '30 Oct 2018 14:54:41', 'Uptime: 28d 22:32:08', and 'Session: 39:15'. A 'Logout' button is on the right.

Four level meters are shown: 'Main MPX' (59.2), 'Main Digital' (-6.9, -7.1), 'IP Audio' (-16.3, -15.1), and 'Output' (59.2, -8.4, -8.4). Each meter has a scale from -70 to 120.

Below the meters are 'Clear System Log' and 'Reload' buttons. The 'Clear System Log' button has a 'Clear' sub-button, and the 'Reload' button has a 'Reload' sub-button.

The system log table below shows the following entries:

2018-10-16 17:12:19	Control	Source Change, Main MPX Input, Auto selected
2018-10-16 17:33:54	System	RTC set: 2018-10-16 17:33:55, diff=1, NTP
2018-10-17 04:33:54	System	RTC set: 2018-10-17 04:33:55, diff=1, NTP
2018-10-17 05:33:54	System	RTC set: 2018-10-17 05:33:55, diff=1, NTP
2018-10-17 08:33:55	System	RTC set: 2018-10-17 08:33:56, diff=1, NTP
2018-10-17 13:01:26	Control	WEB Login, 46.146.207.12, Admin
2018-10-17 13:01:34	Control	Source Change, Main MPX Input, Forced over WEB
2018-10-17 13:01:35	Control	Source Change, AUX MPX Input, Forced over WEB
2018-10-17 13:01:42	Control	Source Change, IP Audio Client, Forced over WEB
2018-10-17 13:01:47	Control	Source Change, Main MPX Input, Forced over WEB
2018-10-17 13:49:08	Control	WEB Logout, 46.146.207.12
2018-10-17 14:34:25	System	RTC set: 2018-10-17 14:34:26, diff=1, NTP
2018-10-17 17:54:36	Control	WEB Login, 79.100.105.36, Admin
2018-10-17 18:36:02	Control	WEB Logout, 79.100.105.36
2018-10-17 23:34:26	System	RTC set: 2018-10-17 23:34:27, diff=1, NTP

On the right side, there is a vertical menu with buttons for: Status, Input, Backup, Stereo Gen, Basic RDS, Dynamic RDS, Output, Dayparts, General, Network, and Other.

To go back to the Other section, press the back button of your web browser.

UPnP discovery in Local Networks

DB8009-MPX implements UPnP which lets you easily find it in your local network. For this purpose your system should have UPnP enabled ([see “UPnP Activation” on page 57](#)). To discover the device follow the next steps:

- Connect the device to the local network.
- Open “My Network Places” on your computer.
- Find the decoder’s icon.
- Double click it to open the DB8009-MPX web interface.

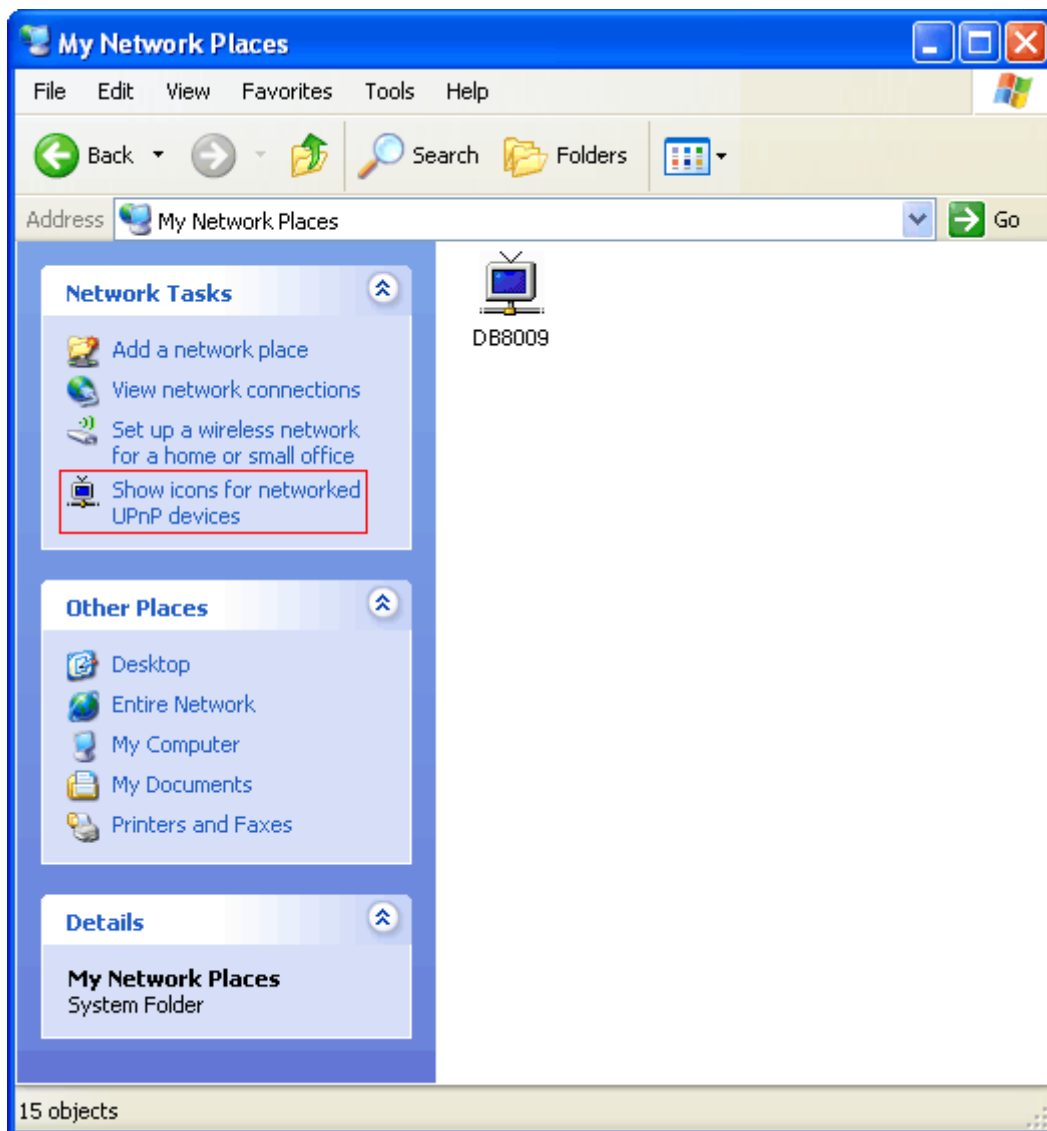

UPnP Activation

NOTE: The following explanations apply to Windows XP SP2 or SP3! If you use another operating system, please contact your system administrator.

Open “My Network Places”. If you have the caption displayed in the picture below, click on it. Then click “Yes” and wait for the process to complete. Now you should see the device. If you still have troubles finding the device, please see

<http://support.microsoft.com/kb/941206> or contact your system administrator.

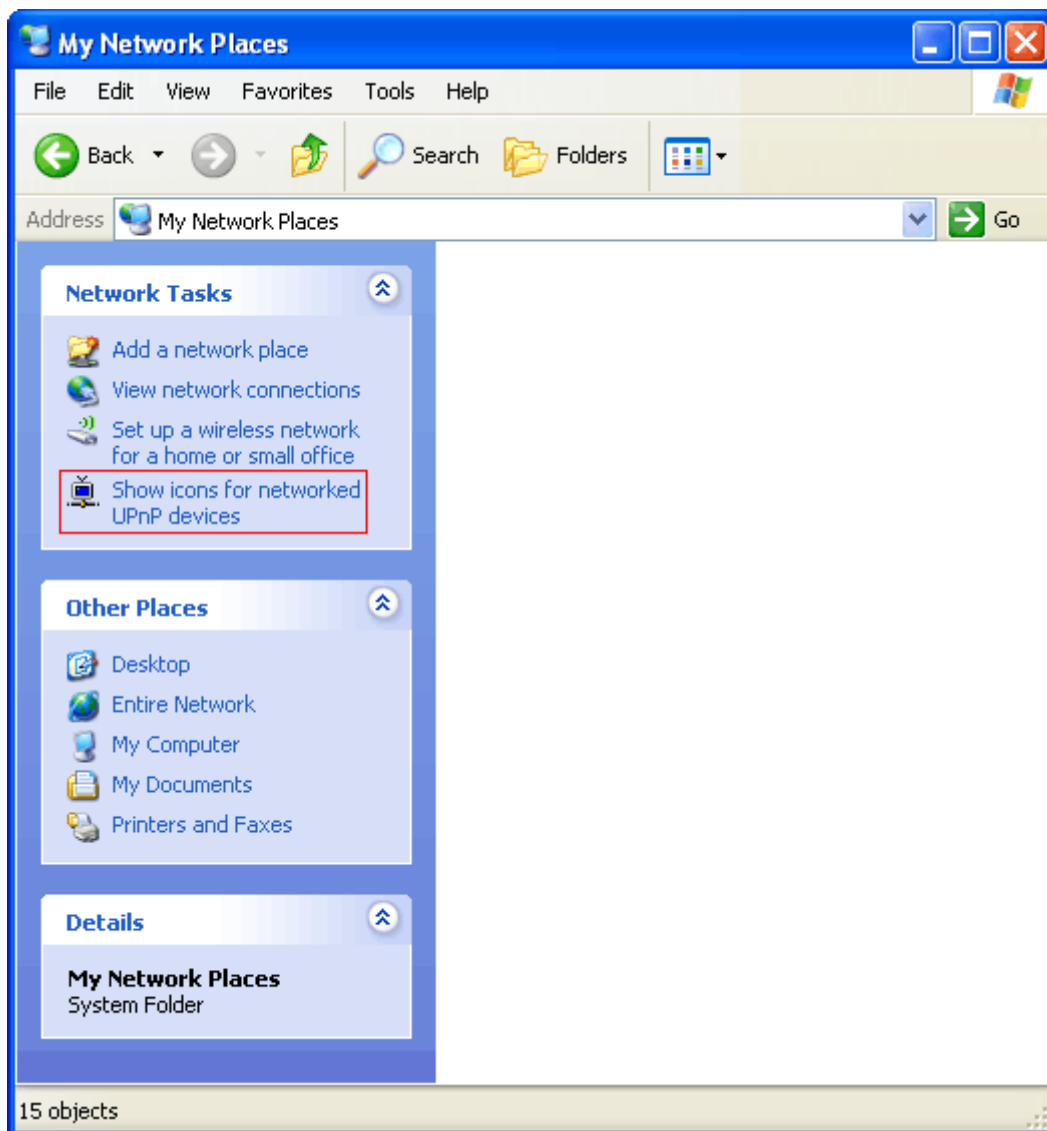

APPENDIX A

RDS: EUROPE VS AMERICA

The European Broadcasting Union (EBU) and its member countries originated the concept of “Radio Data” transmission. The European RDS specification, CENELEC Standard EN50067, was first published in 1984. It was revised in 1986, 1990, 1991 and 1992.

European RDS has grown in use following initial adoption of the Standard. RDS is nearly universal throughout Europe; it is almost impossible to find a European FM broadcasting station that does not carry a radio data subcarrier.

The popularity of RDS in Europe is very much in contrast with initial reluctance on the part of US broadcasters to embrace this technology. This can be ascribed to material differences in broadcasting practices.

Almost without exception, FM broadcasting in the United States is ‘detached’ and independent - each station originates its own programming. America’s National Public Radio might be considered as an exception, though for most of the broadcast day even NPR stations originate, or at least schedule, their own programs.

Most of European broadcasting is similar to the concept of network radio that was common in the US prior to the 1950s. In Europe, a central program originator may have many transmitting facilities of modest power situated throughout the country, at several different frequencies to blanket a designated service area. The European disposition, toward lower-power transmitters can be found on the “local radio” level, as well.

The European concept of a service area equates to the US broadcaster’s market. The subtle difference between these designations further characterizes broadcasting practices and ethics. RDS benefits the European broadcaster through almost an altruistic endeavor to be of service to his listeners. The US broadcaster is marketing his programming and is primarily interested in how he can create additional revenue from RDS.

THE RDS SYSTEM

RDS is a digital data channel, transmitted as a low-level subcarrier above the range of the composite stereo program signal in the FM baseband. The data transmission (baud) rate is comparatively low, yet it is quite robust because of data redundancy and effective error correction.

It is not within the scope of this Manual to cover the details of RDS subcarrier coding and modulation. For this, the reader is directed to the Specification appropriate to his location either the CENELEC EN50067 Specification for Europe or the United States NRSC Specification. Since the Manual will deal with specific implication of RDS implemented with the DB8009-MPX, it is assumed that the user is familiar with the RDS concept.

APPENDIX B.1

PTY Code Description Used in RBDS Mode – North America

PTY	Short Name	Description
1	News	News reports, either local or network in origin.
2	Information	Programming that is intended to impart advice.
3	Sports	Sports reporting, commentary, and/or live event coverage, either local or network in origin.
4	Talk	Call-in and/or interview talk shows either local or national in origin.
5	Rock	Album cuts.
6	Classic Rock	Rock oriented oldies, often mixed with hit oldies, from a decade or more ago.
7	Adult Hits	An up-tempo contemporary hits format with no hard rock and no rap.
8	Soft Rock	Album cuts with a generally soft tempo.
9	Top 40	Current hits, often encompassing a variety of rock styles.
10	Country	Country music, including contemporary and traditional styles.
11	Oldies	Popular music, usually rock, with 80% or greater non-current music.
12	Soft	A cross between adult hits and classical, primarily non-current softrock originals.
13	Nostalgia	Big-band music.
14	Jazz	Mostly instrumental, includes both traditional jazz and more modern “smooth jazz.”
15	Classical	Mostly instrumentals, usually orchestral or symphonic music.
16	Rhythm and Blues	A wide range of musical styles, often called “urban contemporary.”
17	Soft R and B	Rhythm and blues with a generally soft tempo.
18	Foreign Language	Any programming format in a language other than English.
19	Religious Music	Music programming with religious lyrics.
20	Religious Talk	Call-in shows, interview programs, etc. with a religious theme.
21	Personality	A radio show where the on-air personality is the main attraction.
22	Public	Programming that is supported by listeners and/or corporate sponsors instead of advertising.
23	College	Programming produced by a college or university radio station.
24	Spanish Talk	Call-in shows, interview programs, etc. in the Spanish language
25	Spanish Music	Music programming in the Spanish language
26	Hip-Hop	Popular music incorporating elements of rap, rhythm-and-blues, funk, and soul
27-28	Unassigned	
29	Weather	Weather forecasts or bulletins that are non-emergency in nature.
30	Emergency Test	Broadcast when testing emergency broadcast equipment or receivers. Not intended for searching or dynamic switching for consumer receivers. Receivers may, if desired, display “TEST” or “Emergency Test”.
31	Emergency	Emergency announcement made under exceptional circumstances to give warning of events causing danger of a general nature. Not to be used for searching - only used in a receiver for dynamic switching.

NOTE: These definitions can differ slightly between various language versions.

APPENDIX B.2

PTY Code Description Used in RDS Mode – Europe, Asia

PTY	Short Name	Description
1	News	Short accounts of facts, events and publicly expressed views, reportage and actuality.
2	Current affairs	Topical program expanding or enlarging upon the news, generally in different presentation style or concept, including debate, or analysis.
3	Information	Program the purpose of which is to impart advice in the widest sense.
4	Sport	Program concerned with any aspect of sport.
5	Education	Program intended primarily to educate, of which the formal element is fundamental.
6	Drama	All radio plays and serials.
7	Culture	Programs concerned with any aspect of national or regional culture.
8	Science	Programs about the natural sciences and technology.
9	Varied	Used for mainly speech-based programs usually of light-entertainment nature, not covered by other categories. Examples include: quizzes, games, personality interviews.
10	Pop	Commercial music, which would generally be considered to be of current popular appeal, often featuring in current or recent record sales charts.
11	Rock	Contemporary modern music, usually written and performed by young musicians.
12	Easy Listening	Current contemporary music considered to be “easy-listening”, as opposed to Pop, Rock or Classical, or one of the specialized music styles, Jazz, Folk or Country. Music in this category is often but not always, vocal, and usually of short duration.
13	Light classics	Classical Musical for general, rather than specialist appreciation. Examples of music in this category are instrumental music, and vocal or choral works.
14	Serious classics	Performances of major orchestral works, symphonies, chamber music etc., and including Grand Opera.
15	Other music	Musical styles not fitting into any of the other categories. Particularly used for specialist music of which Rhythm & Blues and Reggae are examples.
16	Weather	Weather reports and forecasts and Meteorological information.
17	Finance	Stock Market reports, commerce, trading etc.
18	Children’s programs	For programs targeted at a young audience, primarily for entertainment and interest, rather than where the objective is to educate.
19	Social Affairs	Programs about people and things that influence them individually or in groups. Includes: sociology, history, geography, psychology and society.
20	Religion	Any aspect of beliefs and faiths, involving a God or Gods, the nature of existence and ethics.
21	Phone In	Involving members of the public expressing their views either by phone or at a public forum.
22	Travel	Features and programs concerned with travel to near and far destinations, package tours and travel ideas and opportunities. Not for use for Announcements about problems, delays, or roadworks affecting immediate travel where TP/TA should be used.
23	Leisure	Programs concerned with recreational activities in which the listener might participate. Examples include, Gardening, Fishing, Antique collecting, Cooking, Food & Wine etc.
24	Jazz Music	Polyphonic, syncopated music characterized by improvisation.
25	Country Music	Songs which originate from, or continue the musical tradition of the American Southern States. Characterized by a straightforward melody and narrative story line.
26	National Music	Current Popular Music of the Nation or Region in that country’s language, as opposed to International ‘Pop’ which is usually US or UK inspired and in English.
27	Oldies Music	Music from the so-called “golden age” of popular music.
28	Folk Music	Music which has its roots in the musical culture of a particular nation, usually played on acoustic instruments. The narrative or story may be based on historical events or people.
29	Documentary	Program concerned with factual matters, presented in an investigative style.
30	Alarm Test	Broadcast when testing emergency broadcast equipment or receivers. Not intended for searching or dynamic switching for consumer receivers.. Receivers may, if desired, display “TEST” or “Alarm Test”.
31	Alarm	Emergency announcement made under exceptional circumstances to give warning of events causing danger of a general nature. Not to be used for searching - only used in a receiver for dynamic switching.

APPENDIX C

HOW SHOULD I CONFIGURE THE CONNECTION BETWEEN MY DEVA DEVICE AND AN FTP CLIENT?

In order for a connection to be established the following setting should be applied:

1. FTP Server Settings

The built-in FTP Server has four important parameters that should be configured: Command Port, Data Port, User name and Password. These parameters are to be used in the FTP client's connection configuration. Further information on how to change the FTP Server's settings and their respective default values can be found in the device's User manual.

WE RECOMMEND the usage of FileZilla (<https://filezilla-project.org>). This is a widespread open source software distributed free of charge, hence available for downloading from the Internet.

NOTE: The FTP Server can manage only one connection at a time. The FTP Server works in Passive mode. Hence, the FTP Client should also be set in passive mode.

2. IP Router and Port Translation Settings

If the connection to the device is made through a Network address translation (NAT) router or firewall, the port forwarding feature of the router should be configured. The port forwarding is usually set in the firewall section of the router's menu. As each router has different port forwarding procedure, we recommend you to refer to its complete manual. To allow proper data flow through the router, the FTP Command and FTP Data ports should be open.

NOTE: The FTP port numbers to be used in the port forwarding feature configuration can be found in the device.

3. Example of FTP Client (FileZilla) Settings

In some cases, FileZilla's "Quick connect" feature is not able to connect with the DEVA unit. That is why we recommend the device to be assigned in the program manually.

Enter the FTP Client and go to: **File > Site manager > New Site**. A dialog box requiring obligatory information about the device will appear. Fill in the needed information and press "OK".

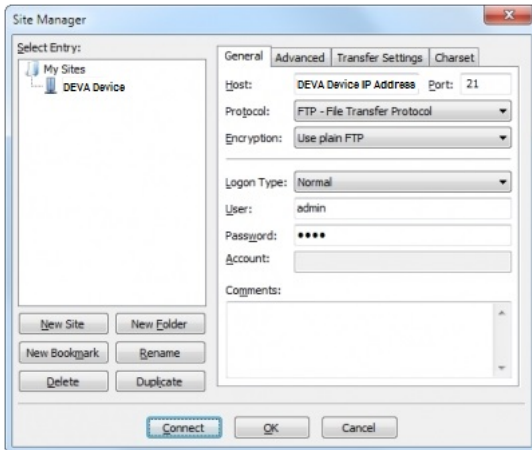

Select "Transfer Settings" sub-menu and apply the settings as shown below:

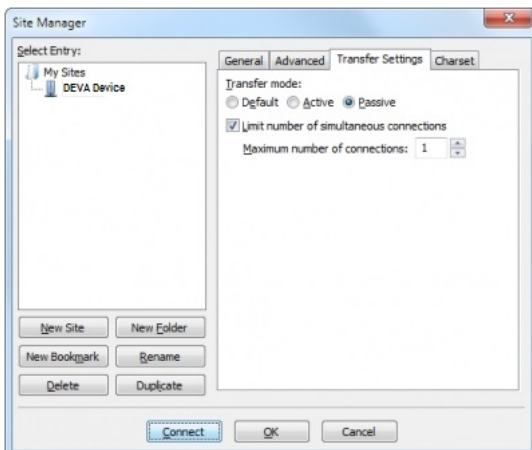

WARRANTY TERMS AND CONDITIONS

I. TERMS OF SALE: DEVA Broadcast Ltd. products are sold with an understanding of “full satisfaction”; that is, full credit or refund will be issued for products sold as new if returned to the point of purchase within 30 days following their receipt, provided that they are returned complete and in an “as received” condition.

II. CONDITIONS OF WARRANTY: The following terms apply unless amended in writing by DEVA Broadcast Ltd.

A. The Warranty Registration Card supplied with this product must be completed and returned to DEVA Broadcast Ltd. within 10 days of delivery.

B. This Warranty applies only to products sold “as new.” It is extended only to the original end-user and may not be transferred or assigned without prior written approval by DEVA Broadcast Ltd.

C. This Warranty does not apply to damage caused by improper mains settings and/or power supply.

D. This Warranty does not apply to damage caused by misuse, abuse, accident or neglect. This Warranty is voided by unauthorized attempts at repair or modification, or if the serial identification label has been removed or altered.

III. TERMS OF WARRANTY: DEVA Broadcast Ltd. products are warranted to be free from defects in materials and workmanship.

A. Any discrepancies noted within TWO YEARS of the date of delivery will be repaired free of charge, or the equipment will be replaced with a new or remanufactured product at DEVA Broadcast Ltd. option.

B. Parts and labor for factory repair required after the two-year Warranty period will be billed at prevailing prices and rates.

IV. RETURNING GOODS FOR FACTORY REPAIR:

A. Equipment will not be accepted for Warranty or other repair without a Return Material Authorization (RMA) number issued by DEVA Broadcast Ltd. prior to its return. An RMA number may be obtained by calling the factory. The number should be prominently marked on the outside of the shipping carton.

B. Equipment must be shipped prepaid to DEVA Broadcast Ltd. Shipping charges will be reimbursed for valid Warranty claims. Damage sustained as a result of improper packing for return to the factory is not covered under terms of the Warranty and may occasion additional charges.

PRODUCT REGISTRATION CARD

- All fields are required, or warranty registration is invalid and void

Your Company Name _____

Contact _____

Address Line 1 _____

Address Line 2 _____

City _____

State/Province _____ ZIP/Postal Code _____

Country _____

E-mail _____ Phone _____ Fax _____

Which DEVA Broadcast Ltd. product did you purchase? _____

Product Serial # _____

Purchase date ____ / ____ / ____ Installation date ____ / ____ / ____

Your signature*

*Signing this warranty registration form you are stating that all the information provided to DEVA Broadcast Ltd. are truth and correct. DEVA Broadcast Ltd. declines any responsibility for the provided information that could result in an immediate loss of warranty for the above specified product(s).

Privacy statement: DEVA Broadcast Ltd. will not share the personal information you provide on this card with any other parties.